

LOCATION: ON THE SIDE OF THE LODGE, WHERE THE LOCATOR IS AT. COORDINATE WITH CEMETERY DIRECTOR FOR EXACT PLACEMENT AND ORIENTATION OF THE MONUMENT.

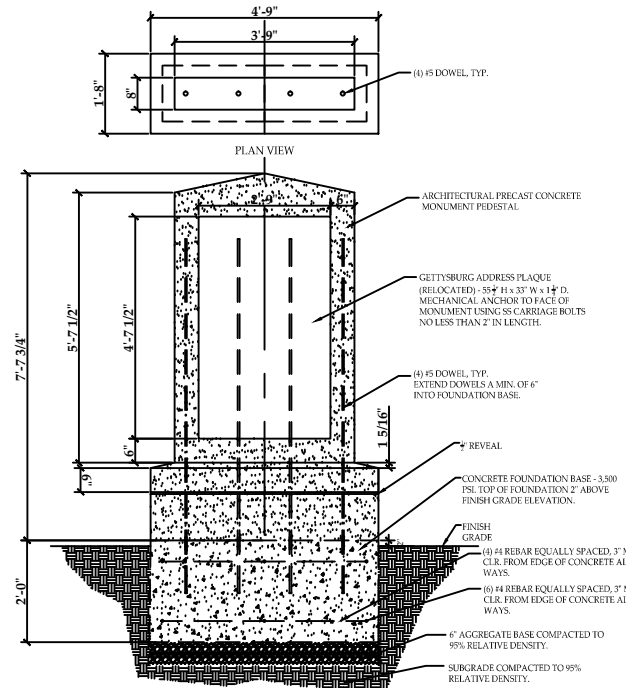

### GETTYSBURG ADDRESS MONUMENT

SCALE  $\frac{1}{4}'' = 1'$

MOBILE NATIONAL CEMETERY  
 GETTYSBURG ADDRESS  
 MONUMENT  
 ATTACHMENT - SOW DRAWING  
 10 FEB 14

**NOTES:**

1. MATERIAL:  
303 PER ASTM A582 OR  
316 PER AMS 5648 OR ASTM A276
2. BOLT SHALL COMPLY WITH ALL DIMENSIONAL REQUIREMENTS OF A 5 INCH LONG, 1/2 - 13UNC, HEX HEAD BOLT PER ASME B18.2.1 UNLESS OTHERWISE STATED.
3. ALL RADII ARE TO BE .01 ± .005 UNLESS OTHERWISE NOTED.
4. PROTECTIVE FINISH 5.4.1 SHALL BE APPLIED IN ACCORDANCE WITH MIL-STD-171

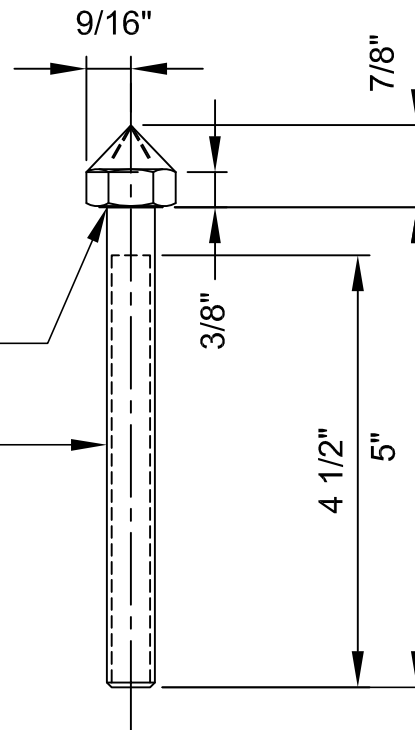
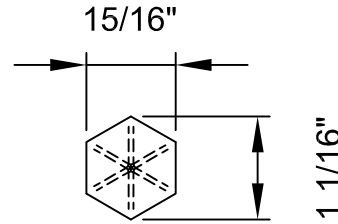

SEE NOTE 5 ASME B18.21 PG 16

1/2 - 13 UNC 2A

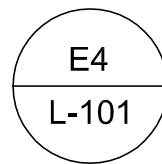
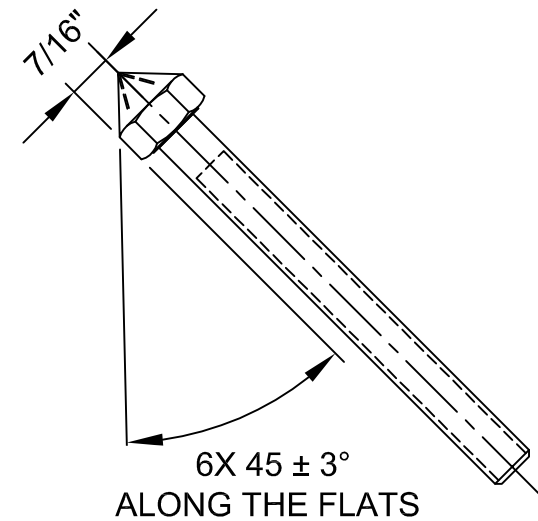

**GETTYSBURG BOLT**

SCALE: 6" = 1'-0"

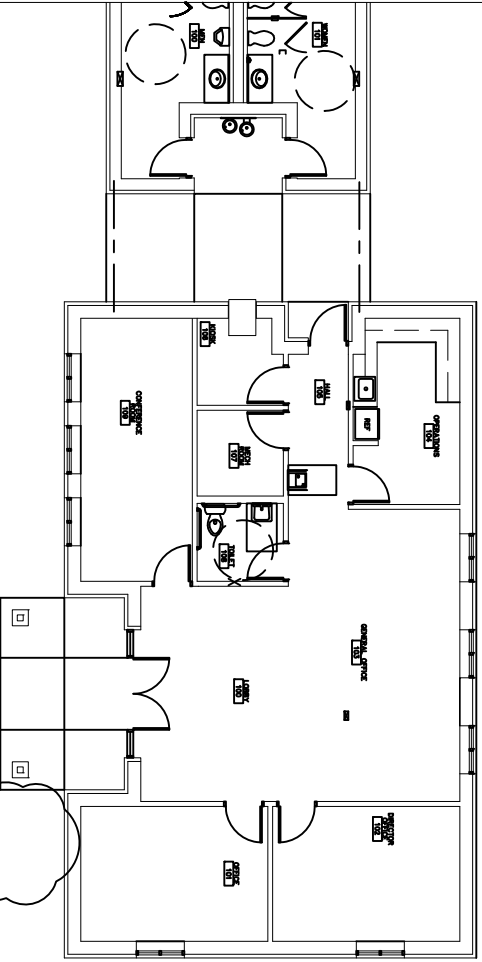

Approximate  
Location

LOCATION  
SCALE  $\frac{1}{4}$ " = 1'

LOCATION: TO THE RIGHT SIDE OF THE ENTRANCE TO THE ADMINISTRATIVE BUILDING. COORDINATE WITH CEMETERY DIRECTOR FOR EXACT PLACEMENT AND ORIENTATION OF THE MONUMENT.

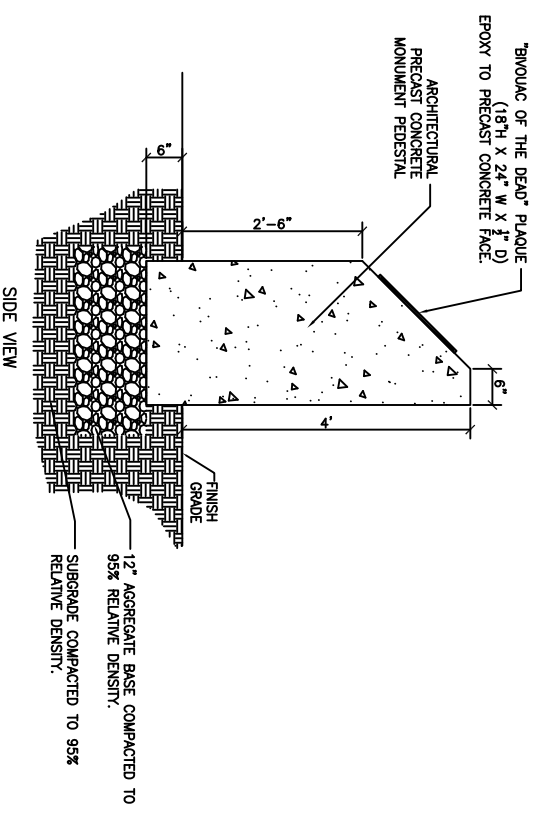
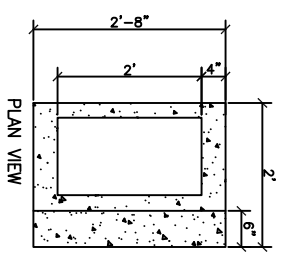

BIVOUAC OF THE DEAD MONUMENT  
SCALE  $\frac{3}{8}$ " = 1'

BARRANCAS NATIONAL  
CEMETERY  
BIVOUAC OF THE DEAD  
MONUMENT  
ATTACHMENT - SOW DRAWING  
14 FEB 14

**SPECIFICATIONS**

**GETTYSBURG ADDRESS MONUMENT AND PLAQUE INSTALLATION @ MOBILE  
NATIONAL CEMETERY AND BIVOUAC OF THE DEAD MONUMENT AND  
PLAQUE INSTALLATION @ BARRANCAS NATIONAL CEMETERY**

**MOBILE, ALABAMA AND PENSACOLA, FLORIDA**

**SECTION 01010**

**GENERAL REQUIREMENTS**

**TABLE OF CONTENTS**

1.1 GENERAL INTENTION .....3

1.2 STATEMENT OF BID ITEM(S) .....4

1.3 SPECIFICATIONS AND DRAWINGS FOR CONTRACTOR .....4

1.4 CONSTRCTION .....4

1.5 FIRE SAFETY .....7

1.6 OPERATIONS AND STORAGE AREAS .....10

1.7 ALTERATIONS .....14

1.8 ENVIRONMENTAL CONTROLS .....15

1.9 PROTECTION OF EXISTING VEGETATION, STRUCTURES, EQUIPMENT,  
UTILITIES, AND IMPROVEMENTS .....15

1.10 RESTORATION .....16

1.11 PHYSICAL DATA .....18

1.12 LAYOUT OF WORK .....18

1.13 AS-BUILT DRAWINGS .....20

1.14 USE OF ROADWAYS .....20

1.15 TEMPORARY TOILETS .....20

SPECIFICATIONS

GETTYSBURG ADDRESS MONUMENT AND PLAQUE INSTALLATION @ MOBILE  
NATIONAL CEMETERY AND BIVOUAC OF THE DEAD MONUMENT AND  
PLAQUE INSTALLATION @ BARRANCAS NATIONAL CEMETERY

MOBILE, ALABAMA AND PENSACOLA, FLORIDA

1.16 AVAILABILITY AND USE OF UTILITY SERVICES .....21

1.17 GOVERNMENT-FURNISHED PROPERTY .....22

1.18 DIGITAL IMAGES .....23

1.19 HISTORIC PRESERVATION.....24

## SPECIFICATIONS

### GETTYSBURG ADDRESS MONUMENT AND PLAQUE INSTALLATION @ MOBILE NATIONAL CEMETERY AND BIVOUAC OF THE DEAD MONUMENT AND PLAQUE INSTALLATION @ BARRANCAS NATIONAL CEMETERY

MOBILE, ALABAMA AND PENSACOLA, FLORIDA

#### 1.1 GENERAL INTENTION

- A. Contractor shall completely prepare site for building operations, including demolition and removal of existing structures, and furnish labor and materials and perform work for providing and installing one (1) Architectural Pre-Cast Monument, light grey in color, atop a concrete foundation and installation of government furnished Gettysburg Address Plaque onto the monument as required by drawings and specifications.
- B. Visits to the site by Bidders may be made only by appointment with the Cemetery Director.
- C. All employees of general contractor and subcontractors shall comply with VA security management program and have in their possession a valid form of identification.
- D. Prior to commencing work, general contractor shall provide proof that a OSHA certified "competent person" (CP) (29 CFR 1926.20(b)(2)) will maintain a presence at the work site whenever the general or subcontractors are present. The competent person will have the authority to ensure that all applicable provisions of OSHA 29 CFR 1910 and 1926 are being adhered to.
- G. Training:

## SPECIFICATIONS

### GETTYSBURG ADDRESS MONUMENT AND PLAQUE INSTALLATION @ MOBILE NATIONAL CEMETERY AND BIVOUAC OF THE DEAD MONUMENT AND PLAQUE INSTALLATION @ BARRANCAS NATIONAL CEMETERY

MOBILE, ALABAMA AND PENSACOLA, FLORIDA

1. All employees of general contractor or subcontractors shall have the 10-hour OSHA certified Construction Safety course and /or other relevant competency training, as determined by VA CP
2. Submit training records of all such employees for approval before the start of work.

#### **1.2 STATEMENT OF BID ITEM(S)**

- A. ITEM I, GENERAL CONSTRUCTION: Work includes general construction, alterations, walks, and necessary removal of existing structures and construction and construction or installation of other items.

#### **1.3 SPECIFICATIONS AND DRAWINGS FOR CONTRACTOR**

- A. AFTER AWARD OF CONTRACT, 15 sets of specifications and drawings will be furnished. These drawings and specifications may consist of those returned by prospective bidders.
- B. Additional sets of drawings may be made by the Contractor, at Contractor's expense, from a reproducible Bond print furnished by the Issuing Office.

#### **1.4 CONSTRUCTION SAFETY REQUIREMENTS**

- A. Security Plan:
  1. The security plan defines both physical and administrative security procedures that will remain effective for the entire duration of the project.

## SPECIFICATIONS

### GETTYSBURG ADDRESS MONUMENT AND PLAQUE INSTALLATION @ MOBILE NATIONAL CEMETERY AND BIVOUAC OF THE DEAD MONUMENT AND PLAQUE INSTALLATION @ BARRANCAS NATIONAL CEMETERY

MOBILE, ALABAMA AND PENSACOLA, FLORIDA

2. The General Contractor is responsible for assuring that all sub-contractors working on the project and their employees also comply with these regulations.
- B. Security Procedures:
1. General Contractor's employees shall not enter the project site without an appropriate badge. They may also be subject to inspection of their personal effects when entering or leaving the project site.
  2. For working outside the "regular hours" as defined in the contract, The General Contractor shall give 3 days notice to the RE/COTR so that security arrangements can be provided for the employees. This notice is separate from any notices required for utility shutdown described later in this section.
  3. No photography of VA premises is allowed without written permission of the RE/COTR.
  4. VA reserves the right to close down or shut down the project site and order General Contractor's employees off the premises in the event of a national emergency. The General Contractor may return to the site only with the written approval of the RE/COTR.
- C. Guards:
1. The General Contractor shall be responsible for the security of the project area and their own property and work.
- D. Document Control:
1. Before starting any work, the General Contractor/Sub Contractors shall submit an electronic security memorandum describing the approach to following goals and maintaining confidentiality of "sensitive information".



## SPECIFICATIONS

### GETTYSBURG ADDRESS MONUMENT AND PLAQUE INSTALLATION @ MOBILE NATIONAL CEMETERY AND BIVOUAC OF THE DEAD MONUMENT AND PLAQUE INSTALLATION @ BARRANCAS NATIONAL CEMETERY

MOBILE, ALABAMA AND PENSACOLA, FLORIDA

2. The General Contractor is responsible for safekeeping of all drawings, project manual and other project information. This information shall be shared only with those with a specific need to accomplish the project.
  3. Certain documents, sketches, videos or photographs and drawings may be marked "Law Enforcement Sensitive" or "Sensitive Unclassified". Secure such information in separate containers and limit the access to only those who will need it for the project. Return the information to the RE/COTR upon request.
  4. These security documents shall not be removed or transmitted from the project site without the written approval of RE/COTR.
  5. All paper waste or electronic media such as CD's and diskettes shall be shredded and destroyed in a manner acceptable to the VA.
  6. Notify RE/COTR immediately when there is a loss or compromise of "sensitive information".
  7. All electronic information shall be stored in a specified location following VA standards and procedures using an Engineering Document Management Software (EDMS).
    - a. Security, access and maintenance of all project drawings, both scanned and electronic shall be performed and tracked through the EDMS system.
    - b. "Sensitive information" including drawings and other documents may be attached to e-mail provided all VA encryption procedures are followed.
- E. Motor Vehicle Restrictions
1. Vehicle authorization request shall be required for any vehicle entering the site and such request shall be submitted 24 hours before the date and time of

SPECIFICATIONS

GETTYSBURG ADDRESS MONUMENT AND PLAQUE INSTALLATION @ MOBILE  
NATIONAL CEMETERY AND BIVOUAC OF THE DEAD MONUMENT AND  
PLAQUE INSTALLATION @ BARRANCAS NATIONAL CEMETERY

MOBILE, ALABAMA AND PENSACOLA, FLORIDA

access. Access shall be restricted to picking up and dropping off materials and supplies.

**1.5 FIRE SAFETY**

A. Applicable Publications: Publications listed below form part of this Article to the extent referenced. Publications are referenced in text by basic designations only.

1. American Society for Testing and Materials (ASTM):
  - E84-2009a .....Surface Burning Characteristics of Building  
Materials
2. National Fire Protection Association (NFPA):
  - 10-2007.....Standard for Portable Fire Extinguishers
  - 30-2008.....Flammable and Combustible Liquids Code
  - 51B-2009 .....Standard for Fire Prevention During Welding,  
Cutting and Other Hot Work
  - 70-2008.....National Electrical Code
  - 241-2009.....Standard for Safeguarding Construction, Alteration,  
and Demolition Operations
3. Occupational Safety and Health Administration (OSHA):
  - 29 CFR 1926 .....Safety and Health Regulations for Construction

B. Fire Safety Plan: Establish and maintain a fire protection program in accordance with 29 CFR 1926. Prior to start of work, prepare a plan detailing project-specific fire safety measures, including periodic status reports, and submit to RE/COTR/Cemetery Director for review for compliance with contract requirements in accordance with Section 01 33 23, SHOP DRAWINGS,

## SPECIFICATIONS

### GETTYSBURG ADDRESS MONUMENT AND PLAQUE INSTALLATION @ MOBILE NATIONAL CEMETERY AND BIVOUAC OF THE DEAD MONUMENT AND PLAQUE INSTALLATION @ BARRANCAS NATIONAL CEMETERY

MOBILE, ALABAMA AND PENSACOLA, FLORIDA

PRODUCT DATA AND SAMPLES. Prior to any worker for the contractor or subcontractor's beginning work, they shall undergo a safety briefing provided by the General Contractor's competent person per OSHA requirements. This briefing shall include information on the construction limits, safety guidelines, means of egress, break areas, work hours, locations of restrooms, use of NCA equipment, etc. Documentation shall be provided to the RE/COTR that individuals have undergone the Contractor's safety briefing.

- C. Site and Building Access: Maintain free and unobstructed access to emergency services and for fire, police and other emergency response forces in accordance with NFPA 241.
- D. Separate temporary facilities, such as trailers, storage sheds, and dumpsters, from existing buildings and new construction by distances in accordance with NFPA 241. For small facilities with less than 6 m (20 feet) exposing overall length, separate by 3m (10 feet).
- E. Temporary Heating and Electrical: Install, use and maintain installations in accordance with 29 CFR 1926, NFPA 241 and NFPA 70.
- G. Means of Egress: Do not block exiting for occupied buildings, including paths from exits to roads. Minimize disruptions and coordinate with RE/COTR/Cemetery Director.
- H. Egress Routes for Construction Workers: Maintain free and unobstructed egress. Inspect daily. Report findings and corrective actions weekly to RE/COTR.
- I. Fire Extinguishers: Provide and maintain extinguishers in construction areas and temporary storage areas in accordance with 29 CFR 1926, NFPA 241 and NFPA 10.

## SPECIFICATIONS

### GETTYSBURG ADDRESS MONUMENT AND PLAQUE INSTALLATION @ MOBILE NATIONAL CEMETERY AND BIVOUAC OF THE DEAD MONUMENT AND PLAQUE INSTALLATION @ BARRANCAS NATIONAL CEMETERY

MOBILE, ALABAMA AND PENSACOLA, FLORIDA

- J. Flammable and Combustible Liquids: Store, dispense and use liquids in accordance with 29 CFR 1926, NFPA 241 and NFPA 30.
- K. Existing Fire Protection: Do not impair automatic sprinklers, smoke and heat detection, and fire alarm systems, except for portions immediately under construction, and temporarily for connections. Request interruptions in accordance with Article, OPERATIONS AND STORAGE AREAS, and coordinate with RE/COTR. All existing or temporary fire protection systems (fire alarms) located in construction areas shall be tested as coordinated with the Cemetery. Parameters for the testing and results of any tests performed shall be recorded by the Cemetery and copies provided to the RE/COTR.
- L. Hot Work: Perform and safeguard hot work operations in accordance with NFPA 241 and NFPA 51B. Coordinate with RE/COTR. Obtain permits from RE/COTR at least 24 hours in advance . Designate Contractor's responsible project-site fire prevention program manager to permit hot work.
- N. Fire Hazard Prevention and Safety Inspections: Inspect entire construction areas weekly. Coordinate with, and report findings and corrective actions weekly to RE/COTR.
- O. Smoking: Smoking is prohibited in and adjacent to construction areas inside existing buildings and additions under construction. In separate and detached buildings under construction, smoking is prohibited except in designated smoking rest areas.
- Q. Dispose of waste and debris in accordance with NFPA 241. Remove from buildings daily.

## SPECIFICATIONS

### GETTYSBURG ADDRESS MONUMENT AND PLAQUE INSTALLATION @ MOBILE NATIONAL CEMETERY AND BIVOUAC OF THE DEAD MONUMENT AND PLAQUE INSTALLATION @ BARRANCAS NATIONAL CEMETERY

MOBILE, ALABAMA AND PENSACOLA, FLORIDA

- P. Perform other construction, alteration and demolition operations in accordance with 29 CFR 1926.

#### 1.6 OPERATIONS AND STORAGE AREAS

- A. The Contractor shall confine all operations (including storage of materials) on Government premises to areas authorized or approved by the RE/COTR. The Contractor shall hold and save the Government, its officers and agents, free and harmless from liability of any nature occasioned by the Contractor's performance.
- B. Temporary buildings (e.g., storage trailers, office trailers) and utilities may be erected by the Contractor only with the approval of the RE/COTR and shall be built with labor and materials furnished by the Contractor without expense to the Government. The temporary buildings and utilities shall remain the property of the Contractor and shall be removed by the Contractor at its expense upon completion of the work. With the written consent of the RE/COTR, the buildings and utilities may be abandoned and need not be removed.
- C. The Contractor shall, under regulations prescribed by the RE/COTR, use only established roadways, or use temporary roadways constructed by the Contractor when and as authorized by the RE/COTR. When materials are transported in prosecuting the work, vehicles shall not be loaded beyond the loading capacity recommended by the manufacturer of the vehicle or prescribed by any Federal, State, or local law or regulation. When it is necessary to cross curbs or sidewalks, the Contractor shall protect them from damage. The Contractor shall repair or pay for the repair of any damaged curbs, sidewalks, or roads. **(FAR 52.236-10)**
- D. Working space and space available for storing materials shall be as determined by the RE/COTR.

## SPECIFICATIONS

### GETTYSBURG ADDRESS MONUMENT AND PLAQUE INSTALLATION @ MOBILE NATIONAL CEMETERY AND BIVOUAC OF THE DEAD MONUMENT AND PLAQUE INSTALLATION @ BARRANCAS NATIONAL CEMETERY

MOBILE, ALABAMA AND PENSACOLA, FLORIDA

- E. Workmen are subject to rules of the Cemetery applicable to their conduct.
- F. Execute work so as to interfere as little as possible with normal functioning of Cemetery as a whole, including operations of utility services, fire protection systems and any existing equipment, and with work being done by others.
  - 1. Do not store materials and equipment in other than assigned areas.
  - 2. Schedule delivery of materials and equipment to immediate construction working areas within buildings in use by the Department of Veterans Affairs in quantities sufficient for not more than two work days. Provide unobstructed access to the Cemetery areas required to remain in operation.
  - 3. The Contractor shall take all measures and provide all material necessary for protecting existing equipment and property in affected areas of construction against dust and debris, so that equipment and affected areas to be used in the Cemetery's operations will not be hindered. The Contractor shall permit access to Department of Veterans Affairs personnel through other construction areas which serve as routes of access to such affected areas and equipment. Coordinate alteration work in areas occupied by Department of Veterans Affairs so that Cemetery operations will continue during the construction period.
- G. Utilities Services: Maintain existing utility services for the Cemetery at all times. Provide temporary facilities, labor, materials, equipment, connections, and utilities to assure uninterrupted services. Where necessary to cut existing water, sewer or air pipes, or conduits, wires, cables, etc. of utility services or of fire protection systems and communications systems (including telephone), they shall

## SPECIFICATIONS

### GETTYSBURG ADDRESS MONUMENT AND PLAQUE INSTALLATION @ MOBILE NATIONAL CEMETERY AND BIVOUAC OF THE DEAD MONUMENT AND PLAQUE INSTALLATION @ BARRANCAS NATIONAL CEMETERY

MOBILE, ALABAMA AND PENSACOLA, FLORIDA

be cut and capped at suitable places where shown; or, in absence of such indication, where directed by RE/COTR.

1. No utility service such as water, gas, steam, sewers or electricity, or fire protection systems and communications systems may be interrupted without prior approval of RE/COTR. Electrical work shall be accomplished with all affected circuits or equipment de-energized. When an electrical outage cannot be accomplished, work on any energized circuits or equipment shall not commence without the RE/COTR, and Cemetery Director's prior knowledge and written approval..
2. The Contractor shall submit a request to interrupt any such services to RE/COTR, and Cemetery Director, in writing, 48 hours in advance of proposed interruption. Request shall state reason, date, exact time of, and approximate duration of such interruption.
3. The Contractor will be advised (in writing) of approval of request, or of which other date and/or time such interruption will cause least inconvenience to operations of the Cemetery . Interruption time approved by the Cemetery may occur at other than Contractor's normal working hours.
4. Major interruptions of any system must be requested, in writing, at least 15 calendar days prior to the desired time and shall be performed as directed by the RE/COTR.
5. In case of a contract construction emergency, service will be interrupted on approval of RE/COTR. Such approval will be confirmed in writing as soon as practical.

## SPECIFICATIONS

### GETTYSBURG ADDRESS MONUMENT AND PLAQUE INSTALLATION @ MOBILE NATIONAL CEMETERY AND BIVOUAC OF THE DEAD MONUMENT AND PLAQUE INSTALLATION @ BARRANCAS NATIONAL CEMETERY

MOBILE, ALABAMA AND PENSACOLA, FLORIDA

6. Whenever it is required that a connection fee be paid to a public utility provider for new permanent service to the construction project, for such items as water, sewer, electricity, gas or steam, payment of such fee shall be the responsibility of the Government and not the Contractor.
- L. To minimize interference of construction activities with flow of Cemetery traffic, comply with the following:
1. Keep roads, walks and entrances to grounds, to parking and to occupied areas of buildings clear of construction materials, debris and standing construction equipment and vehicles.
  2. Method and scheduling of required cutting, altering and removal of existing roads, walks and entrances must be approved by the RE/COTR.
- N. Coordinate the work for this contract with other construction operations as directed by RE/COTR. This includes the scheduling of traffic and the use of roadways, as specified in Article, USE OF ROADWAYS.
- O. Coordination of Construction with Cemetery Director: The burial activities at a National Cemetery shall take precedence over construction activities. The Contractor must cooperate and coordinate with the Cemetery Director, through the RE/COTR, in arranging construction schedule to cause the least possible interference with Cemetery activities in actual burial areas. Construction noise during the interment services shall not disturb the service. Trucks and workmen shall not pass through the service area during this period:
1. The Contractor is required to discontinue his work sufficiently in advance of Easter Sunday, Mother's Day, Father's Day, Memorial Day, Veteran's Day



## SPECIFICATIONS

### GETTYSBURG ADDRESS MONUMENT AND PLAQUE INSTALLATION @ MOBILE NATIONAL CEMETERY AND BIVOUAC OF THE DEAD MONUMENT AND PLAQUE INSTALLATION @ BARRANCAS NATIONAL CEMETERY

MOBILE, ALABAMA AND PENSACOLA, FLORIDA

and/or Federal holidays, to permit him to clean up all areas of operation adjacent to existing burial plots before these dates.

2. Cleaning up shall include the removal of all equipment, tools, materials and debris and leaving the areas in a clean, neat condition.

#### **1.7 ALTERATIONS**

- A. Survey: Before any work is started, the Contractor shall make a thorough survey with the RE/COTR in which alterations occur and areas which are anticipated routes of access, and furnish a report, signed by to the Contracting Officer. This report shall list by rooms and spaces:
  1. Shall note any discrepancies between drawings and existing conditions at site.
  2. Shall designate areas for working space, materials storage and routes of access to areas within buildings where alterations occur and which have been agreed upon by Contractor and RE/COTR.
- B. Any items required by drawings to be either reused or relocated or both, found during this survey to be nonexistent, or in opinion of RE/COTR, to be in such condition that their use is impossible or impractical, shall be furnished and/or replaced by the Contractor with new items in accordance with specifications which will be furnished by the Government. Provided the contract work is changed by reason of this subparagraph B, the contract will be modified accordingly, under provisions of clause entitled "DIFFERING SITE CONDITIONS" (FAR 52.236-2) and "CHANGES" (FAR 52.243-4 and VAAR 852.236-88).

## SPECIFICATIONS

### GETTYSBURG ADDRESS MONUMENT AND PLAQUE INSTALLATION @ MOBILE NATIONAL CEMETERY AND BIVOUAC OF THE DEAD MONUMENT AND PLAQUE INSTALLATION @ BARRANCAS NATIONAL CEMETERY

MOBILE, ALABAMA AND PENSACOLA, FLORIDA

- C. Re-Survey: Thirty days before expected partial or final inspection date, the Contractor and RE/COTR together shall make a thorough re-survey of the areas involved. They shall furnish a report on conditions then existing, of surfaces and site furnishings as compared with conditions of same as noted in first condition survey report:
1. Re-survey report shall also list any damage caused by the Contractor to such surfaces and site furnishings, despite protection measures; and, will form the basis for determining extent of repair work required of the Contractor to restore damage caused by the Contractor's workmen in executing work of this contract.
- D. Protection: Provide the following protective measures:
1. Temporary protection against damage for portions of existing structures and grounds where work is to be done, materials handled and equipment moved and/or relocated.

#### **1.8 ENVIRONMENTAL CONTROLS**

- A. Final Cleanup:
1. Upon completion of the project, or as work progresses, remove all construction debris from construction area.

#### **1.9 PROTECTION OF EXISTING VEGETATION, STRUCTURES, EQUIPMENT, UTILITIES, AND IMPROVEMENTS**

- A. The Contractor shall preserve and protect all structures, equipment, and vegetation (such as trees, shrubs, and grass) on or adjacent to the work site, which are not to be removed and which do not unreasonably interfere with the work

## SPECIFICATIONS

### GETTYSBURG ADDRESS MONUMENT AND PLAQUE INSTALLATION @ MOBILE NATIONAL CEMETERY AND BIVOUAC OF THE DEAD MONUMENT AND PLAQUE INSTALLATION @ BARRANCAS NATIONAL CEMETERY

MOBILE, ALABAMA AND PENSACOLA, FLORIDA

required under this contract. The Contractor shall only remove trees when specifically authorized to do so, and shall avoid damaging vegetation that will remain in place. If any limbs or branches of trees are broken during contract performance, or by the careless operation of equipment, or by workmen, the Contractor shall trim those limbs or branches with a clean cut and paint the cut with a tree-pruning compound as directed by the RE/COTR.

- B. The Contractor shall protect from damage all existing improvements and utilities at or near the work site and on adjacent property of a third party, the locations of which are made known to or should be known by the Contractor. The Contractor shall repair any damage to those facilities, including those that are the property of a third party, resulting from failure to comply with the requirements of this contract or failure to exercise reasonable care in performing the work. If the Contractor fails or refuses to repair the damage promptly, the RE/COTR may have the necessary work performed and charge the cost to the Contractor. **(FAR 52.236-9)**
- C. Refer to Section 01 57 19, TEMPORARY ENVIRONMENTAL CONTROLS, for additional requirements on protecting vegetation, soils and the environment. Refer to Articles, "Alterations", "Restoration", and "Operations and Storage Areas" for additional instructions concerning repair of damage to structures and site improvements.

#### 1.10 RESTORATION

- A. Remove, cut, alter, replace, patch and repair existing work as necessary to install new work. Except as otherwise shown or specified, do not cut, alter or remove

## SPECIFICATIONS

### GETTYSBURG ADDRESS MONUMENT AND PLAQUE INSTALLATION @ MOBILE NATIONAL CEMETERY AND BIVOUAC OF THE DEAD MONUMENT AND PLAQUE INSTALLATION @ BARRANCAS NATIONAL CEMETERY

MOBILE, ALABAMA AND PENSACOLA, FLORIDA

any structural work, and do not disturb any ducts, plumbing, steam, gas, or electric work without approval of the RE/COTR. Existing work to be altered or extended and that is found to be defective in any way, shall be reported to the RE/COTR before it is disturbed. Materials and workmanship used in restoring work, shall conform in type and quality to that of original existing construction, except as otherwise shown or specified.

- B. Upon completion of contract, deliver work complete and undamaged. Existing work (walls, ceilings, partitions, floors, mechanical and electrical work, lawns, paving, roads, walks, etc.) disturbed or removed as a result of performing required new work, shall be patched, repaired, reinstalled, or replaced with new work, and refinished and left in as good condition as existed before commencing work.
- C. At the Contractor's own expense, the Contractor shall immediately restore to service and repair any damage caused by the Contractor's workmen to existing piping and conduits, wires, cables, etc., of utility services or of fire protection systems and communications systems (including telephone) which are indicated on drawings and which are not scheduled for discontinuance or abandonment.
- D. Expense of repairs to such utilities and systems not shown on drawings or locations of which are unknown will be covered by adjustment to contract time and price in accordance with clause entitled "CHANGES" (FAR 52.243-4 and VAAR 852.236-88) and "DIFFERING SITE CONDITIONS" (FAR 52.236-2).

## SPECIFICATIONS

### GETTYSBURG ADDRESS MONUMENT AND PLAQUE INSTALLATION @ MOBILE NATIONAL CEMETERY AND BIVOUAC OF THE DEAD MONUMENT AND PLAQUE INSTALLATION @ BARRANCAS NATIONAL CEMETERY

MOBILE, ALABAMA AND PENSACOLA, FLORIDA

#### 1.11 PHYSICAL DATA

- A. Data and information furnished or referred to is for the Contractor's information. The Government shall not be responsible for any interpretation of or conclusion drawn from the data or information by the Contractor.
- B. Government does not guarantee that other materials will not be encountered nor that proportions, conditions or character of several materials will not vary from those indicated by explorations. Bidders are expected to examine site of work and, after investigation, decide for themselves character of materials and make their bids accordingly. Upon proper coordination to Department of Veterans Affairs, bidders will be permitted to make subsurface explorations of their own at site.

#### 1.12 LAYOUT OF WORK

- A. The Contractor shall lay out the work from Government established base lines and bench marks indicated on the drawings, and shall be responsible for all measurements in connection with the layout. The Contractor shall furnish, at the Contractor's own expense, all stakes, templates, platforms, equipment, tools, materials, and labor required to lay out any part of the work. The Contractor shall be responsible for executing the work to the lines and grades that may be established or indicated by the RE/COTR. The Contractor shall also be responsible for maintaining and preserving all stakes and other marks established by the RE/COTR until authorized to remove them. If such marks are destroyed by the Contractor or through Contractor's negligence before their removal is

## SPECIFICATIONS

### GETTYSBURG ADDRESS MONUMENT AND PLAQUE INSTALLATION @ MOBILE NATIONAL CEMETERY AND BIVOUAC OF THE DEAD MONUMENT AND PLAQUE INSTALLATION @ BARRANCAS NATIONAL CEMETERY

MOBILE, ALABAMA AND PENSACOLA, FLORIDA

authorized, the RE/COTR may replace them and deduct the expense of the replacement from any amounts due or to become due to the Contractor.

#### **(FAR 52.236-17)**

- B. Establish and plainly mark center lines for each building and/or addition to each existing building, lines for each gravesite control monument, and such other lines and grades that are reasonably necessary to properly assure that location, orientation, and elevations established for each such structure and/or addition, roads, parking lots, gravesite control monuments, are in accordance with lines and elevations shown on contract drawings.
- C. Following completion of general mass excavation and before any other permanent work is performed, establish and plainly mark (through use of appropriate batter boards or other means) sufficient additional survey control points or system of points as may be necessary to assure proper alignment, orientation, and grade of all major features of work. The Survey shall include, but not be limited to, location of lines and grades of footings, exterior walls, center lines of columns in both directions, major utilities and elevations of floor slabs:
  - 1. Such additional survey control points or system of points thus established shall be checked and certified by a registered land surveyor or registered civil engineer. Furnish such certification to the RE/COTR before any work (such as footings, floor slabs, columns, walls, utilities and other major controlling features) is placed.
- F. The Contractor shall perform the surveying and layout work of this and other articles and specifications in accordance with the provisions of Article "Professional Surveying Services".

## SPECIFICATIONS

### GETTYSBURG ADDRESS MONUMENT AND PLAQUE INSTALLATION @ MOBILE NATIONAL CEMETERY AND BIVOUAC OF THE DEAD MONUMENT AND PLAQUE INSTALLATION @ BARRANCAS NATIONAL CEMETERY

MOBILE, ALABAMA AND PENSACOLA, FLORIDA

#### **1.13 AS-BUILT DRAWINGS**

- A. The Contractor shall maintain two full size sets of as-built drawings which will be kept current during construction of the project, which will include all contract changes, modifications and clarifications.
- B. All variations shall be shown in the same general detail as used in the contract drawings. To insure compliance, as-built drawings shall be made available for the RE/COTR's review, as often as requested.
- C. The Contractor shall deliver two approved completed sets of as-built drawings to the RE/COTR within 15 calendar days after each completed phase and after the acceptance of the project by the RE/COTR.
- D. Paragraphs A, B, & C shall also apply to all shop drawings.

#### **1.14 USE OF ROADWAYS**

- A. For hauling, use only established public roads and roads on Cemetery // property and, when authorized by the RE/COTR, such temporary roads which are necessary in the performance of contract work. Temporary roads shall be constructed by the Contractor at the Contractor's expense. When necessary to cross curbing, sidewalks, or similar construction, they must be protected by well-constructed bridges.

#### **1.15 TEMPORARY TOILETS**

## SPECIFICATIONS

### GETTYSBURG ADDRESS MONUMENT AND PLAQUE INSTALLATION @ MOBILE NATIONAL CEMETERY AND BIVOUAC OF THE DEAD MONUMENT AND PLAQUE INSTALLATION @ BARRANCAS NATIONAL CEMETERY

MOBILE, ALABAMA AND PENSACOLA, FLORIDA

- A. Provide where directed, (for use of all Contractor's workmen) ample temporary sanitary toilet accommodations with suitable sewer and water connections, or when approved by RE/COTR provide suitable dry closets where directed. Keep such places clean and free from flies, and all connections and appliances connected therewith are to be removed prior to completion of contract, and premises left perfectly clean.
- B. Contractor may have for use of the Contractor's workmen, such toilet accommodations as may be assigned to the Contractor by the Cemetery. The Contractor shall keep such places clean and be responsible for any damage done thereto by the Contractor's workmen. Failure to maintain satisfactory condition in toilets will deprive the Contractor of the privilege to use such toilets.

#### **1.16 AVAILABILITY AND USE OF UTILITY SERVICES**

- A. The Government shall make all reasonably required amounts of utilities available to the Contractor from existing outlets and supplies, as specified in the contract. The amount to be paid by the Contractor for chargeable electrical services shall be the prevailing rates charged to the Government. The Contractor shall carefully conserve any utilities furnished without charge.
- B. The Contractor, at Contractor's expense and in a workmanlike manner satisfactory to the RE/COTR, shall install and maintain all necessary temporary connections and distribution lines, and all meters required to measure the amount of electricity used for the purpose of determining charges. Before final acceptance of the work by the Government, the Contractor shall remove all the temporary connections, distribution lines, meters, and associated paraphernalia.



## SPECIFICATIONS

### GETTYSBURG ADDRESS MONUMENT AND PLAQUE INSTALLATION @ MOBILE NATIONAL CEMETERY AND BIVOUAC OF THE DEAD MONUMENT AND PLAQUE INSTALLATION @ BARRANCAS NATIONAL CEMETERY

MOBILE, ALABAMA AND PENSACOLA, FLORIDA

- C. The Contractor shall install meters at the Contractor's expense and furnish the Cemetery // a monthly record of the Contractor's usage of electricity as hereinafter specified.
- D. Electricity (for Construction and Testing): Furnish all temporary electric services.
  - 1. Obtain electricity by connecting to the Cemetery electrical distribution system. The Contractor shall meter and pay for electricity required for electric cranes and hoisting devices, electrical welding devices and any electrical heating devices providing temporary heat. Where not available the contractor shall supply power via portable generators at own expense.
- F. Water (for Construction and Testing): Furnish temporary water service.
  - 1. Obtain water by connecting to the Cemetery water distribution system. Provide reduced pressure backflow preventer at each connection. Water is available at no cost to the Contractor.
  - 2. Maintain connections, pipe, fittings and fixtures and conserve water-use so none is wasted. Failure to stop leakage or other wastes will be cause for revocation (at RE/COTR's discretion) of use of water from the Cemetery's system.

#### **1.17 GOVERNMENT-FURNISHED PROPERTY**

- A. The Government shall deliver to the Contractor, the Government-furnished property shown on the drawings.
- B. Equipment furnished by the Government to be installed by the Contractor will be furnished to the Contractor at the Cemetery.

## SPECIFICATIONS

### GETTYSBURG ADDRESS MONUMENT AND PLAQUE INSTALLATION @ MOBILE NATIONAL CEMETERY AND BIVOUAC OF THE DEAD MONUMENT AND PLAQUE INSTALLATION @ BARRANCAS NATIONAL CEMETERY

MOBILE, ALABAMA AND PENSACOLA, FLORIDA

- C. The Contractor shall be prepared to receive this equipment from the Government and store or place such equipment not less than 90 days before Completion Date of project.
- D. Storage space for equipment will be provided by the Government and the Contractor shall be prepared to unload and store such equipment therein upon its receipt at the Cemetery //
- E. Notify RE/COTR in writing, 60 days in advance, of date on which Contractor will be prepared to receive equipment furnished by Government. Arrangements will then be made by the Government for delivery of equipment.
  - 1. Immediately upon delivery of equipment, the Contractor shall arrange for a joint inspection thereof with a representative of the Government. At such time the Contractor shall acknowledge receipt of equipment described, make notations, and immediately furnish the Government representative with a written statement as to its condition or shortages.
  - 2. The Contractor thereafter is responsible for such equipment until such time as acceptance of contract work is made by the Government.
- F. Completely assemble and install the Government furnished equipment in place ready for proper operation in accordance with specifications and drawings.

#### **1.18 DIGITAL IMAGES**

- A. During construction period through completion, furnish COTR sufficient digital photographs showing construction progress through e-mail. After the project acceptance, the Contractor shall submit an electronic device (such as CD, USB storage

## SPECIFICATIONS

### GETTYSBURG ADDRESS MONUMENT AND PLAQUE INSTALLATION @ MOBILE NATIONAL CEMETERY AND BIVOUAC OF THE DEAD MONUMENT AND PLAQUE INSTALLATION @ BARRANCAS NATIONAL CEMETERY

MOBILE, ALABAMA AND PENSACOLA, FLORIDA

device, etc.) containing all pictures taking during construction.

#### **1.19 HISTORIC PRESERVATION**

Where the Contractor or any of the Contractor's employees, prior to, or during the construction work, are advised of or discover any possible archeological, historical and/or cultural resources, the Contractor shall immediately notify the RE/COTR verbally, and then with a written follow up.

E N D O F S E C T I O N

## SPECIFICATIONS

### GETTYSBURG ADDRESS MONUMENT AND PLAQUE INSTALLATION @ MOBILE NATIONAL CEMETERY AND BIVOUAC OF THE DEAD MONUMENT AND PLAQUE INSTALLATION @ BARRANCAS NATIONAL CEMETERY

MOBILE, ALABAMA AND PENSACOLA, FLORIDA

#### SECTION 02870

#### SITE FURNISHINGS

##### PART 1 - GENERAL

###### 1.1. SUMMARY

- A. This Section includes the following:
  - 1. Gettysburg Address Monument
- B. Related Sections: The following sections contain requirements that relate to this section
  - 1. Division 3 Section 03300 - "Cast-In-Place Concrete" for concrete for footings, and pads
  - 2. Division 3 Section 3450 - Plant-Precast Architectural Concrete
  - 3. Division 7 Section 07920 – Joint Sealants

###### 1.2. SUBMITTALS

- A. General: Submit the following in accordance with Conditions of Contract and Division 1 Specification Sections.
  - 1. Shop drawings showing product components and installation.
    - a. Mounting of Address plaque (Cast aluminum) on to precast concrete monument

###### 1.3. QUALITY ASSURANCE

- A. Comply with Manufacturer's recommendations.

##### PART 2 - PRODUCTS

###### 2.1. MATERIALS

- A. Gettysburg Address Plaque- Government furnished, contractor installed

02870 - 1

Site Furnishings

## SPECIFICATIONS

### GETTYSBURG ADDRESS MONUMENT AND PLAQUE INSTALLATION @ MOBILE NATIONAL CEMETERY AND BIVOUAC OF THE DEAD MONUMENT AND PLAQUE INSTALLATION @ BARRANCAS NATIONAL CEMETERY

MOBILE, ALABAMA AND PENSACOLA, FLORIDA

#### PART 3 - EXECUTION

##### 3.1. INSTALLATION

###### A. General:

1. Field verify all dimensions and conditions affecting the work.
2. Obtain approval of layout by Contracting Officer's Technical Representative prior to installation.
3. All work shall be left clean and free from warp, twist, open joints and other defects
4. Install all work plumb, level, true and straight according to manufacturer's specifications.
5. Protect installed work during remaining construction operations. Repair marred or damaged finishes matching adjacent surfaces or replace with new matching materials. No tool marks or wood splitting will be permitted.

###### B. Plaques -

1. Fasten to precast concrete surface with stainless steel vandal proof fasteners and mounting method.
2. Clean exposed surfaces and protect until final acceptance

##### 3.2. FIELD QUALITY CONTROL

- A. Clean all surfaces of the structure of grime, dirt, mud, and handling prints.
- B. Inspect all surfaces for damage. Consult with manufacturer and Contracting Officer's Technical Representative prior to repair to making repair avoid the voiding of any warrantee or unsightly blemish.

END OF SECTION

## SPECIFICATIONS

### GETTYSBURG ADDRESS MONUMENT AND PLAQUE INSTALLATION @ MOBILE NATIONAL CEMETERY AND BIVOUAC OF THE DEAD MONUMENT AND PLAQUE INSTALLATION @ BARRANCAS NATIONAL CEMETERY

MOBILE, ALABAMA AND PENSACOLA, FLORIDA

#### SECTION 03210

#### REINFORCING STEEL

##### PART 1 - GENERAL

##### 1.1. GENERAL REQUIREMENTS

- A. Requirements of Division 1 apply to all work of this Section.

##### 1.2. SCOPE

- A. Unless noted otherwise, furnish and install reinforcing for all concrete, including dowels, chairs, spacers, bolsters, etc., necessary for supporting and fastening reinforcement in place as shown on the Drawings and specified herein.

##### 1.3. RELATED WORK

- A. Concrete Formwork: Section 03100.
- B. Cast-In-Place Concrete: Section

0330

##### 1.4. QUALITY ASSURANCE

- A. General:
  - 1. Acceptable Manufacturers: Regularly engaged in the manufacture of steel bar and welded wire fabric reinforcing.
  - 2. Installer Qualifications: Installation shall be done only by an installation firm normally engaged in this business. All work shall be performed by qualified mechanics working under an experienced supervisor.
  - 3. Welding Qualifications: Welding procedures, welding

## SPECIFICATIONS

### GETTYSBURG ADDRESS MONUMENT AND PLAQUE INSTALLATION @ MOBILE NATIONAL CEMETERY AND BIVOUAC OF THE DEAD MONUMENT AND PLAQUE INSTALLATION @ BARRANCAS NATIONAL CEMETERY

#### MOBILE, ALABAMA AND PENSACOLA, FLORIDA

operators and welders shall be qualified in accordance with  
AWS D1 .4 - "Structural Welding Code Reinforcing Steel".

- a. Welders whose work fails to pass inspection shall  
be re-qualified before performing further welding.

4. Reinforcement Work shall conform to ACI 301 and IBC Section 1907,  
as minimum standards.
5. Allowable Tolerances:
  - a. Fabrication:
    - 1) Sheared length: 1 inch.
    - 2) Depth of truss bars: Plus 0., minus  $\frac{1}{8}$ -inch.
    - 3) Ties: Plus or minus  $\frac{1}{8}$ -inch.
    - 4) All other bends: Plus or minus 1 inch.
  - b. Placement:
    - 1) Concrete cover to form surfaces: Plus or minus  $\frac{1}{4}$ -  
inch.
    - 2) Minimum spacing between bars: Plus or minus  $\frac{1}{4}$ -  
inch.
    - 3) Crosswise of members: Spaced evenly within 2  
inches of stated separation.
    - 4) Lengthwise of members: Plus or minus 2 inches.
  - c. Maximum bar movement to avoid interference with  
other reinforcing steel, conduits, or embedded items: 2 bar  
diameters.

B. Standards and References: (Latest Edition unless otherwise noted):

1. American Concrete Institute (ACI).
  - a. ACI 301 - "Specifications for Structural Concrete for  
Buildings".
  - b. ACI 315 - "Details and Detailing of Concrete Reinforcing".
  - c. ACI318 – "Building Code Requirements for Reinforced  
Concrete"
2. American Society for Testing and Materials (ASTM).
  - a. ASTM A82 - "Cold Drawn Wire for Concrete

## SPECIFICATIONS

### GETTYSBURG ADDRESS MONUMENT AND PLAQUE INSTALLATION @ MOBILE NATIONAL CEMETERY AND BIVOUAC OF THE DEAD MONUMENT AND PLAQUE INSTALLATION @ BARRANCAS NATIONAL CEMETERY

MOBILE, ALABAMA AND PENSACOLA, FLORIDA

- Reinforcement".
  - b. ASTM A185 - "Welded Steel Wire Fabric for Concrete Reinforcement".
  - c. ASTM A615 - "Deformed and Plain Billet-Steel Bars for Concrete Reinforcement".
  - d. ASTM A706 – "Low Alloy Steel Deformed Bars for Concrete Reinforcement".
  - 3. Concrete Reinforcing Steel Institute (CRSI) - "Manual of Standard Practice".
  - 4. 2006 International Building Code (IBC).
- C. Submittals: (Submit under provisions of Section 01300)
- 1. Shop Drawings: Prepare in accordance ACI 315. Indicate bending diagrams, assembly diagrams, splicing and laps of bars and shapes, dimensions and details of bar reinforcing and assemblies. Correctness of all reinforcing requirements and work is the responsibility of Contractor. Identify such shop drawings with reference thereon to sheet and detail numbers from Contract Drawings.
    - a. Do not use scaled dimensions from Contract Drawings in determining the lengths of reinforcing bars.
    - b. No reinforcing steel shall be fabricated without approved shop drawings.
    - c. One of the required submittal copies shall be reproducible transparency.
    - d. Any deviations from the contract documents must be clearly indicated as a deviation on the shop drawings.
    - e. Areas of high congestion, including member joints and embed locations shall be fully detailed to verify clearances and assembly parameters and coordination with other trades.



## SPECIFICATIONS

### GETTYSBURG ADDRESS MONUMENT AND PLAQUE INSTALLATION @ MOBILE NATIONAL CEMETERY AND BIVOUAC OF THE DEAD MONUMENT AND PLAQUE INSTALLATION @ BARRANCAS NATIONAL CEMETERY

MOBILE, ALABAMA AND PENSACOLA, FLORIDA

2. Certified mill test reports of supplied reinforcing indicating chemical and physical analysis. Tensile and bend tests shall be performed by the mill in accordance with ASTM A61 5.
3. Product Data:
  - a. Manufacturer's specifications and installation instructions for splice devices.
  - b. Bar Supports.
4. Certificates of Compliance with specified standards:
  - a. Reinforcing bars.
  - b. Welded wire fabric.
  - c. Welding electrodes.
5. Samples: Only as requested by Architect.

#### D. Tests and Inspections:

1. A testing program is required prior to start of construction. Testing program to be done in Compliance with the 2006 IBC requirements and in collaboration with Testing Laboratory, Design team, contractor, owner and submitted for review by the agency in charge of building enforcement. Requirements below are minimum requirements; additional requirements may be required in final testing program.
2. All reinforcing steel whose properties are not identifiable by mill test reports shall be tested in accordance with ASTM A615. One Series of tests for each missing report to be borne by the Contractor.
3. When inspections are indicated for reinforcement placement on the Structural drawings, a special inspector shall be employed to inspect reinforcing placement per IBC Section 1704
4. When tests are indicated for reinforcing steel on the structural drawings, the reinforcing steel used shall be tested in accordance with ASTM A61 5. One tensile and one bend test for each 2-1/2 tons of steel or fraction thereof, shall be made.
5. Inspect shop and field welding in accordance with AWS D1.4, including checking materials, equipment, procedure and welder

## SPECIFICATIONS

### GETTYSBURG ADDRESS MONUMENT AND PLAQUE INSTALLATION @ MOBILE NATIONAL CEMETERY AND BIVOUAC OF THE DEAD MONUMENT AND PLAQUE INSTALLATION @ BARRANCAS NATIONAL CEMETERY

MOBILE, ALABAMA AND PENSACOLA, FLORIDA

qualification as well as the welds. Inspector will use non-destructive testing or any other aid to visual inspection that he deems necessary to assure himself of the adequacy of the weld.

6. Tests and inspection shall be performed by Owners testing agency except when needed to justify rejected work, in which case the cost of retests and re-inspection shall be borne by the Contractor.

#### 1.5. PRODUCT DELIVERY, STORAGE AND HANDLING

- A. Deliver reinforcement to project site in bundles marked with metal tags indicating bar size and length.
- B. Handle and store materials to prevent contamination.
- C. Store reinforcement in a manner that will prevent excessive rusting or coating with grease, oil, dirt, and other objectionable materials. Storage shall be in separate piles or racks so as to avoid confusion or loss of identification after bundles are broken.

#### 1.6. Deliver and store welding electrodes in accordance with AWS

D12.1.

## PART 2 - PRODUCTS

### 2.1. MATERIALS

- A. Reinforcement Bars: ASTM A615, Grade 40 for No. 3 and smaller bars; ASTM A615, Grade 60 for No. 4 and larger bars.
  1. Bar reinforcement to be welded shall meet chemical requirements of ASTM A706.
- B. Stirrups and Ties: ASTM A615, Grade 60 for No.4 and larger bars, ASTM A615, Grade 40 for No. 3 and smaller bars.
- C. Steel Dowels: Same grade as bars to which dowels are connected.

## SPECIFICATIONS

### GETTYSBURG ADDRESS MONUMENT AND PLAQUE INSTALLATION @ MOBILE NATIONAL CEMETERY AND BIVOUAC OF THE DEAD MONUMENT AND PLAQUE INSTALLATION @ BARRANCAS NATIONAL CEMETERY

MOBILE, ALABAMA AND PENSACOLA, FLORIDA

- D. Welded wire Fabric: ASTM A185.
- E. Tie Wires: FS-QQ-W-461, annealed steel, black, 16 gauge minimum.
- F. Welding Electrodes: AWS D1 .4, low hydrogen, E70XX series.
- G. Bar Supports:
  - 1. Typical, unless noted otherwise; CRSI Class 2 wire supports.
    - a. Do not use wood, brick or other objectionable materials.
    - b. Do not use galvanized supports.
  - 2. Supports placed against ground: Pre-cast concrete blocks not less than 4 inches square with embedded wire.
- H. Mechanical Couplers: Comply with ACI 318 section 12.14.3.

### PART 3 - EXECUTION

#### 3.1. FABRICATION

- A. Shop fabricate reinforcement to meet requirements of Drawings.
- B. Fabricate reinforcement in accordance with the requirements of ACI 315 where specific details are not shown or where Drawings and Specifications are not more demanding.
- C. Steel reinforcement shall not be bent or straightened in a manner that will injure the material. Bars with kinks or bends not shown on the Drawings shall not be used. Heating of bars for bending will not be permitted.
- D. Reinforcing shall not be field bent or straightened without structural engineer's review.
- E. Provide offsets in rebar (1:6 maximum) where required to maintain clearances.

#### 3.2. CONDITION OF SURFACES

## SPECIFICATIONS

### GETTYSBURG ADDRESS MONUMENT AND PLAQUE INSTALLATION @ MOBILE NATIONAL CEMETERY AND BIVOUAC OF THE DEAD MONUMENT AND PLAQUE INSTALLATION @ BARRANCAS NATIONAL CEMETERY

MOBILE, ALABAMA AND PENSACOLA, FLORIDA

- A. Examine surfaces and conditions receiving or affecting the work. Do not proceed until unsuitable conditions have been corrected.

#### 3.3. GENERAL

- A. Concrete shown without reinforcing shall be reinforced as similar parts shown with reinforcing except where concrete is specifically noted to be unreinforced.

#### 3.4. PLACEMENT

- A. All reinforcement shall be accurately set in place, lapped, spliced, spaced rigidly and securely held in place and tied with specified wire at all splices and crossing points. All wire tie ends shall point away from the form. Carefully locate all dowel steel to align with wall and column steel.
  - 1. Bars shall be in long lengths with laps and splices as shown. Offset laps in adjacent bars. Place steel with clearances and cover as shown. Bar laps shall be as indicated on the Drawings. Tie all laps and intersections with the specified wire.
  - 2. Maintain clear space between parallel bars not less than 1-1/2 times nominal diameter, but in no case shall clear space be less than 1-1/2 times maximum size concrete aggregate.
  - 3. Reinforcing dowels for slabs shall be placed as detailed. Sleeves may be used if reviewed by the Structural Engineer before installation. Install dowel through all construction and expansion joints for all slabs on grade.
- B. Bar Supports: Support and securely fasten bars with chairs, spacers and ties to prevent displacement by construction loads or placement of concrete beyond the tolerances specified. Conform to CRSI as a minimum standard.
- C. Steel Adjustment:
  - 1. Move within allowable tolerances to avoid interference with other reinforcing steel, conduits, or embedded items.

## SPECIFICATIONS

### GETTYSBURG ADDRESS MONUMENT AND PLAQUE INSTALLATION @ MOBILE NATIONAL CEMETERY AND BIVOUAC OF THE DEAD MONUMENT AND PLAQUE INSTALLATION @ BARRANCAS NATIONAL CEMETERY

MOBILE, ALABAMA AND PENSACOLA, FLORIDA

2. Do not move bars beyond allowable without concurrence of Structural Engineer.
3. Do not heat, bend, or cut bars without concurrence of Structural Engineer.
4. Reinforcement shall not be bent after being embedded in hardened concrete.

D. Splices:

1. Splice reinforcing as shown.
2. Lap Splices: Tie securely with wire to prevent displacement of splices during placement of concrete.
3. Splice Devices: Install in accordance with manufacturer's written instructions. Obtain Structural Engineer's review before using.
4. Do not splice bars except at locations shown without concurrence of Structural Engineer.
  - a. Where splices in addition to those indicated are required, indicate location on shop drawings clearly and highlight "for Engineer's approval".

E. Welding:

1. Welding is not permitted unless specifically detailed on Drawings or approved by Engineer.
2. Employ shielding metal-arc method and meet requirements of AWS D1.4.
3. Welding is not permitted on bars where the carbon equivalent is unknown or is determined to exceed 0.55.
4. Welding shall not be done within two bar diameters of any bent portion of a bar which has been bent cold.
5. Welding of crossing bars is not permitted.

F. Welded Wire Fabric: Install in long lengths, lapping 24 inches at end splices and one mesh at side splices. Offset laps in adjacent widths. Place fabric in approximately the middle of the slab thickness unless shown otherwise on the Drawings by dimension.

## SPECIFICATIONS

### GETTYSBURG ADDRESS MONUMENT AND PLAQUE INSTALLATION @ MOBILE NATIONAL CEMETERY AND BIVOUAC OF THE DEAD MONUMENT AND PLAQUE INSTALLATION @ BARRANCAS NATIONAL CEMETERY

MOBILE, ALABAMA AND PENSACOLA, FLORIDA

Wire tie lap joints at 12-inch centers. Use concrete blocks to support mesh in proper position.

- G. Reinforcement shall be free of mud, oil or other materials that may reduce bond at the time concrete is placed. Reinforcement with tightly adhered rust or mill scale will be accepted without cleaning provided that rusting has not reduced dimensions and weights below applicable standards. Remove loose rust.
- H. Protection against rust:
  - 1. Where there is danger of rust staining adjacent surfaces, wrap reinforcement with impervious tape or otherwise prevent rust staining.
  - 2. Remove protective materials and clean reinforcement as required before proceeding with concrete placement.
- I. Drawing Notes: Refer to notes on Drawings for additional reinforcement requirements.
- J. Mechanical and Electrical Drawings: Refer to Mechanical and Electrical Drawings for formed concrete requiring reinforcing steel. All such steel shall be included under the work of this Section.

END OF SECTION

## SPECIFICATIONS

### GETTYSBURG ADDRESS MONUMENT AND PLAQUE INSTALLATION @ MOBILE NATIONAL CEMETERY AND BIVOUAC OF THE DEAD MONUMENT AND PLAQUE INSTALLATION @ BARRANCAS NATIONAL CEMETERY

MOBILE, ALABAMA AND PENSACOLA, FLORIDA

#### SECTION 03300

#### CAST-IN-PLACE CONCRETE

##### PART 1 - GENERAL

##### 1.1. GENERAL REQUIREMENTS

- A. Requirements of Division 1 apply to all Work of this Section.

##### 1.2. SCOPE

- A. Furnish, place and finish cast in place concrete and related work as indicated on the Drawings and specified here.
  - 1. Install miscellaneous metal and other items furnished by other trades to be installed in concrete work.
  - 2. Provide facilities for job curing of test cylinders and transporting to Testing Laboratory.
  - 3. Provide grouting of steel base plates as indicated on the Drawings and specified here.

##### 1.3. RELATED WORK

- A. Concrete Formwork: Section 03100.
- B. Reinforcing Steel: Section 03210.
- C. Structural Steel: Section 05120.

##### 1.4. QUALITY ASSURANCE

- A. Standards and References: (Latest Edition unless otherwise noted)
  - 1. 2006 International Building Code (IBC).
  - 2. AMERICAN CONCRETE INSTITUTE (ACI)
    - a. ACI 117 - Standard Tolerances for Concrete Construction and Materials
    - b. ACI 211.1 - Standard Practice for Selecting Proportions for Normal, Heavyweight, and Mass Concrete

## SPECIFICATIONS

### GETTYSBURG ADDRESS MONUMENT AND PLAQUE INSTALLATION @ MOBILE NATIONAL CEMETERY AND BIVOUAC OF THE DEAD MONUMENT AND PLAQUE INSTALLATION @ BARRANCAS NATIONAL CEMETERY

#### MOBILE, ALABAMA AND PENSACOLA, FLORIDA

- c. ACI 211.2 - Standard Practice for Selecting Proportions for Structural Lightweight Concrete
  - d. ACI 301 - Structural Concrete for Buildings
  - e. ACI 305R - Hot Weather Concreting
  - f. ACI 318 - Building Code Requirements for Reinforced Concrete
3. AMERICAN SOCIETY FOR TESTING AND MATERIALS (ASTM)
- a. ASTM C 31 - Making and Curing Concrete Test Specimens in the Field
  - b. ASTM C 33 - Concrete Aggregates
  - c. ASTM C 39 - Compressive Strength of Cylindrical Concrete Specimens
  - d. ASTM C 42 - Obtaining and Testing Drilled Cores and Sawed Beams of Concrete
  - e. ASTM C 94 - Ready-Mixed Concrete
  - f. ASTM C 143 - Slump of Hydraulic Cement Concrete
  - g. ASTM C 150 - Portland Cement
  - h. ASTM C 172 - Sampling Freshly Mixed Concrete by the Volumetric Method
  - i. ASTM C 192 - Making and Curing Concrete Test Specimens in the Laboratory
  - j. ASTM C 260 - Air-Entraining Admixtures for Concrete
  - k. ASTM C 330 - Lightweight Aggregates for Structural Concrete
  - l. ASTM C 494 - Chemical Admixtures for Concrete
  - m. ASTM C 618 - Fly Ash and Raw or Calcined Natural Pozzolan for Use as a Mineral Admixture in Portland Cement Concrete
  - n. ASTM C157 - Length Change of Hardened Hydraulic-Cement Mortar and Concrete
- B. Submittals:
- 1. Concrete mix designs. See "Mix Design" below. Include results of test data used to establish proportions.



## SPECIFICATIONS

### GETTYSBURG ADDRESS MONUMENT AND PLAQUE INSTALLATION @ MOBILE NATIONAL CEMETERY AND BIVOUAC OF THE DEAD MONUMENT AND PLAQUE INSTALLATION @ BARRANCAS NATIONAL CEMETERY

#### MOBILE, ALABAMA AND PENSACOLA, FLORIDA

2. Certificates of Compliance from Manufacturer
  - a. Cement
  - b. Aggregates
  - c. Admixtures.
3. Data regarding hardeners and sealers.
4. Grout samples for sacked surface textures and colors upon Architects request only.
5. Layout drawings for construction, control and expansion joints.
6. Transit-mix delivery slips:
  - a. Keep record at the job site showing time and place of each pour of concrete, together with transit-mix delivery slips certifying contents of the pour.
  - b. Make the record available to the Architect for his inspection upon request.
  - c. Upon completion of this portion of the work, deliver the record and the delivery slips to the Architect.
7. See Section 03210 for reinforcing steel submittals.

#### C. Tests and Inspections:

1. A testing program is required prior to start of construction. Testing program to be done in Compliance with the 2006 IBC requirements and in collaboration with Testing Laboratory, Design team, contractor, owner and submitted for review by the agency in charge of building enforcement. Requirements below are minimum requirements; additional requirements may be required in final testing program.
2. If concrete tests are indicated as required on the Structural Drawings, the following tests shall be made by a recognized testing laboratory selected by the Owner and approved by the building official. All tests shall be in accordance with the previously mentioned standards. A complete record of all tests and inspections shall be kept per IBC Section 1903.1.
  - a. Compressive Strength: Make and cure in accordance with ASTM C-31. Test in accordance with ASTM C-39 and IBC Section 1905.6.

## SPECIFICATIONS

### GETTYSBURG ADDRESS MONUMENT AND PLAQUE INSTALLATION @ MOBILE NATIONAL CEMETERY AND BIVOUAC OF THE DEAD MONUMENT AND PLAQUE INSTALLATION @ BARRANCAS NATIONAL CEMETERY

MOBILE, ALABAMA AND PENSACOLA, FLORIDA

- 1) A record shall be made of time and of locations of concrete from which samples were taken.
  - 2) Four identical cylinders shall be taken from each pour of 150 cubic yards or 5000 square feet or part thereof, being placed each day per IBC Section 1905.6.2. One cylinder shall be tested at age 7 days, and two at age 28 days unless otherwise specified. Preserve remaining cylinder for future use.
  - b. Drying Shrinkage: (applies to lightweight concrete only unless noted otherwise)
    - 1) A record shall be made of time cylinders and of locations of concrete from which samples were taken.
    - 2) Three identical 4" x 4" x 11" specimens shall be made from same concrete as used in structure. Percent of shrinkage shall be reported at 21 days after 7 day moist curing period. Average results of 3 specimens shall be used as the accepted value. The value for laboratory cast specimens shall not exceed .075%. If field test specimens are used in lieu of laboratory specimens, a tolerance of +33% may be used.
    - 3) Test specimens in accordance with ASTM C157.
  - c. Concrete consistency (slump) shall be tested in accordance with ASTM C143.
3. If concrete inspections are indicated as required on the Structural Drawings, provide full time inspection per IBC Section 1704 during the taking of test specimens and during the placing of all concrete required to possess a compressive strength greater than 2500 psi at 28 days.
  4. See Section 03210 for reinforcing steel tests and inspections.

## SPECIFICATIONS

### GETTYSBURG ADDRESS MONUMENT AND PLAQUE INSTALLATION @ MOBILE NATIONAL CEMETERY AND BIVOUAC OF THE DEAD MONUMENT AND PLAQUE INSTALLATION @ BARRANCAS NATIONAL CEMETERY

MOBILE, ALABAMA AND PENSACOLA, FLORIDA

#### PART 2 - PRODUCTS

##### 2.1. MATERIAL

- A. Portland Cement: ASTM C 150, Type I or Type II. One brand of cement shall be used throughout to maintain uniform color for all exposed concrete.
- B. Concrete Aggregate: Fine and coarse aggregates shall be regarded as separate ingredients. Each size of coarse aggregate, as well as combination of sizes when two or more are used, shall conform to grading requirements of appropriate ASTM Standards and ACI 318.
  - 1. Concrete Aggregates for Standard Weight Concrete: ASTM C 33. Aggregate shall be crushed granite or Perkins type.
  - 2. Concrete Aggregates for Lightweight Concrete: ASTM C330 to produce concrete weighing no more than 110 pcf at 28 days. Aggregate shall be vacuum saturated expanded shale as produced through the rotary kiln method.
- C. Water: Clean and free from injurious amounts of oil, acids, alkali, organic matter and other deleterious substances; suitable for domestic consumption per ACI 318.
- D. Admixtures shall be subject to prior approval by the Architect, in accordance with ACI 318, Calcium Chloride is not permitted.
  - 1. Water Reducing
    - a. ASTM C494 Type A - for use in cool weather.
    - b. ASTM C494 Type D - for use in hot weather.
  - 2. Air Entraining
    - a. Conform to ASTM C 260
  - 3. Fly Ash
    - a. Conform to ASTM C 618
  - 4. Mid-Range Water-Reducers
    - a. Master Builders "Polyheed" or approved equal.
  - 5. Water Resisting

## SPECIFICATIONS

### GETTYSBURG ADDRESS MONUMENT AND PLAQUE INSTALLATION @ MOBILE NATIONAL CEMETERY AND BIVOUAC OF THE DEAD MONUMENT AND PLAQUE INSTALLATION @ BARRANCAS NATIONAL CEMETERY

#### MOBILE, ALABAMA AND PENSACOLA, FLORIDA

- a. Moxie 1800 Super Admix by Moxie International or approved equal formulated to resist moisture vapor migration and alkali efflorescence.
    6. Fly Ash Pozzolan
      - a. Conforming to ASTM A-618 Class F.
  - E. Slab on Grade Vapor Retarder
    1. Vapor Retarder must have the following qualities:
      - a. 10 mil thickness minimum
      - b. WVTR less than 0.008 as tested by ASTM E 96
      - c. ASTM E 1745 Class A (Plastics)
    2. Vapor Retarder Products
      - a. Stego Wrap Vapor Retarder by STEGO INDUSTRIES LLC.
      - b. W.R. Meadows Premoulded Membrane with Plasmatic Core.
      - c. Zero-Perm by Alumiseal.
    3. Vapor Retarder Tape
      - a. Water Vapor Transmission Rate :ASTM E 96, 0.3 perms or lower
      - b. Minimum 8-mils thick
      - c. Minimum 4 inches wide
  - F. Sand: Clean, dry, well graded.
  - G. Abrasive aggregate for non-slip finish: Fused aluminum oxide grits, graded 12/30. Use factory-graded rustproof and non-glazing material that is unaffected by freezing, moisture and cleaning materials.
    1. Products offered by manufacturers to comply with the above requirements include: A-H Alox; Anti-Hydro Waterproofing Co., Toxgrip; Toch Div. - Carboline, or approved equal.
  - H. Expansion Joint Filler:

## SPECIFICATIONS

### GETTYSBURG ADDRESS MONUMENT AND PLAQUE INSTALLATION @ MOBILE NATIONAL CEMETERY AND BIVOUAC OF THE DEAD MONUMENT AND PLAQUE INSTALLATION @ BARRANCAS NATIONAL CEMETERY

#### MOBILE, ALABAMA AND PENSACOLA, FLORIDA

1. Joint fill shall be a preformed non-extruded resilient filler, saturated with bituminous materials and conforming to ASTM D 1751. Products shall be equivalent to Burke "Fiber Expansion Joint", W.R. Meadows "Fibrated Expansion Joint Filler", or approved equal.
- I. Bonding Agent: Sonneborn "Sonobond"; the Euclid Chemical Company "EucoWeld"; Larsen Products Corp., "Weld-Crete" or approved equivalent.
- J. Concrete Sealer: Cure and Seal, as manufactured by the Euclid Chemical Company "Aqua-Cure VOX", Sonneborn "Kure-N-Seal WB", Burke "SpartanCote", W.R. Meadows "Intex" or approved equal conforming to ASTM C-309, Type I, Class B requirements, and conforming to State Air Resources Board VOC Regulations.
- K. Concrete Hardener/Sealer: Clear, water soluble, sprayable in-organic silicate based hardener/sealer or acrylic co-polymer resin. Products shall be equal to Euclid Chemical Company "Eucosil", Burke "Spartan-Cote", Sonneborn "Sonosil", W.R. Meadows "Pena-Lith", or approved equal and must conform to State Air Resources Board VOC Regulations.
- L. Concrete Cure: Water based curing compound conforming to ASTM C-309, Type 1, Class A and B, and AASHTO Specification M-148; Type 1, Class A and B requirements, and State Air Resources Board VOC Regulations. Product shall be equivalent to Euclid Chemical Company "Kurez DR VOX", Burke "No. 1127" or "Aqua-Resin Cure", W.R. Meadows "1100 Clear", or approved equal. Because of the wide variety of paints and adhesives for carpeting and resilient tile in use, contact the manufacturer of the flooring system for application approval of all curing compounds.
- M. Concrete Dry Shake Floor Hardener: Free flowing powder applied prior to smooth steel trowel finish in accordance with manufacturer's requirements. Products shall be equal to Euclid Chemical Company "Surflex" or approved equal
- N. Non-Shrink Grout: See Section 2.2.A.4

## SPECIFICATIONS

### GETTYSBURG ADDRESS MONUMENT AND PLAQUE INSTALLATION @ MOBILE NATIONAL CEMETERY AND BIVOUAC OF THE DEAD MONUMENT AND PLAQUE INSTALLATION @ BARRANCAS NATIONAL CEMETERY

MOBILE, ALABAMA AND PENSACOLA, FLORIDA

- O. Anchor Bolts: All anchor bolts cast in concrete shall be headed bolts with cut threads conforming to ASTM A307 or ASTM A36 or ASTM A572.50 as indicated on drawings.
- P. Expansion Anchors: All expansion bolts installed in concrete shall be KB-III expansion bolts as manufactured by Hilti Inc. See Structural Drawings for installation requirements and tension testing requirements as applicable. See Drawings for special head requirements as needed. Substitution of other brands or anchors shall proceed only after written approval from the Structural Engineer and the Building Official has been obtained.

#### 2.2. CONCRETE

##### A. Concrete Mixes:

###### 1. Type A Concrete:

- a. Strength: 3000 lbs. per square inch at 28 days.
- b. Maximum Aggregate Size: 1-1/2 inch.
- c. Cement Content: As determined by mix design (ACI 318).
- d. 5.0 sacks per yard minimum.
- e. Maximum Water to Cement Ratio: 0.58
- f. Admixture: Water Reducing.
- g. Weight: 145 lbs. per cubic foot
- h. Maximum Fly Ash content as a percentage of total cementitious material: 15%
- i. Use for unexposed foundation concrete except as otherwise specified. At Contractor's option, Type B concrete may be substituted for this.

###### 2. Type B Concrete:

- a. Strength: 3500 lbs. per square inch at 28 days.
- b. Maximum Aggregate Size: 1 inch.
- c. Minimum Cement Content: As determined by mix design. (ACI 318)
- d. 5.5 sacks per yard minimum.

## SPECIFICATIONS

### GETTYSBURG ADDRESS MONUMENT AND PLAQUE INSTALLATION @ MOBILE NATIONAL CEMETERY AND BIVOUAC OF THE DEAD MONUMENT AND PLAQUE INSTALLATION @ BARRANCAS NATIONAL CEMETERY

MOBILE, ALABAMA AND PENSACOLA, FLORIDA

- e. Maximum Water to Cement Ratio: 0.45
  - f. Admixture: Water reducing.
  - g. Weight: 145 lbs. per cubic foot
  - h. Use for building slab on grade
  - i. Maximum Fly Ash content as a percentage of total cementitious material: 15%
3. Type C Concrete:
- a. Strength: 4000 lbs. per square inch at 28 days.
  - b. Maximum Aggregate Size: 1 inch.
  - c. Minimum Cement Content: As required by mix design (ACI 318).
  - d. 6.5 sacks per yard minimum.
  - e. Maximum Water to Cement Ratio: 0.50
  - f. Admixture: Water reducing.
  - g. Weight: 145 lbs. per cubic foot
  - h. Use for concrete cast-in-place walls, exterior paving, sidewalks, curb, gutters, columns, beams and overhead structural slabs except as otherwise specified
  - i. Maximum Fly Ash content as a percentage of total cementitious material: 15%
4. Type E Concrete:
- a. Strength: 2500 lbs. per square inch at 28 days.
  - b. Maximum Aggregate Size: 1 inch.
  - c. Minimum Cement Content: 5 sacks per cubic yard.
  - d. Maximum Water to Cement Ratio: 0.60
  - e. Admixture: Water reducing. Water resisting at floor slabs (verify with owner).
  - f. Weight: 145 lbs. per cubic foot.
  - g. Use for mechanical and electrical pads, miscellaneous non-structural slabs on grade.
  - h. Maximum Fly Ash content as a percentage of total cementitious material: 15%
5. Grout shall be non-shrink, non-metallic, flowable Type "713" or "928" by Master Builders.

## SPECIFICATIONS

### GETTYSBURG ADDRESS MONUMENT AND PLAQUE INSTALLATION @ MOBILE NATIONAL CEMETERY AND BIVOUAC OF THE DEAD MONUMENT AND PLAQUE INSTALLATION @ BARRANCAS NATIONAL CEMETERY

#### MOBILE, ALABAMA AND PENSACOLA, FLORIDA

- a. Non shrink grout equivalent to US Mix Products Co. "Premium Grout" may be used only where covered by earth, concrete, or masonry.
  - b. Acceptance by Architect required before using.
  - c. Use for grouting and/or drypacking of column base plates (Section 05120) and other locations as indicated on the Drawings
- B. Consistency of Concrete: Concrete slump, measured in accordance with ASTM C 143, shall fall within following limits.
1. For General concrete placement: 3 inch plus or minus 1 inch.
  2. Mixes employing the specified mid-range water reducer shall provide a measured slump not to exceed 7 inch +1 inch after dosing, 2 inch +1 inch before dosing.
  3. Concrete slump shall be taken at point of placement. Use water reducing admixtures as required to provide a workable consistency for pump mixers. Water shall not be added at the jobsite without written review by the structural engineer.
- C. Mix Design:
1. Initial mix design shall be prepared for Type A, Type B and Type C concrete by recognized testing laboratory (approved by Architect) in accordance with IBC Section 1905.3 or IBC Section 1905.4. In the event that additional mix designs are required due to depletion of aggregate sources, aggregate not conforming to Specifications, or at request of Contractor, these mixes shall be prepared as above.
  2. Contractor shall notify the Testing Laboratory and Architect of intent to use concrete pumps to place concrete so that mix designs can be modified accordingly.
  3. Fly ash shall not exceed the percentages of the total cementitious material listed in the Concrete Mixes above.
  4. Provide 6% air entrainment typical for exterior concrete exposed to freeze-thaw cycles.
  5. Owner's testing laboratory shall review all mix design before submittal.



## SPECIFICATIONS

### GETTYSBURG ADDRESS MONUMENT AND PLAQUE INSTALLATION @ MOBILE NATIONAL CEMETERY AND BIVOUAC OF THE DEAD MONUMENT AND PLAQUE INSTALLATION @ BARRANCAS NATIONAL CEMETERY

MOBILE, ALABAMA AND PENSACOLA, FLORIDA

#### D. Mixing:

1. Equipment: All concrete shall be machine mixed. Provide adequate equipment and facilities for accurate measurement and control of materials.
2. Method of Mixing:
  - a. Transit Mixing: Comply with ASTM C 94. Ready mixed concrete shall be used throughout, except as specified below.
  - b. On-Site Mixing: Use only if method of storing material, mixing of material and type of mixing equipment is approved by Architect. Approval of site mixing does not relieve Contractor of any other requirements of Specifications.
  - c. Mixing shall be in accordance with IBC Section 1905.8.
3. Mixing Time: After mix water has been added, concrete shall be mixed not less than 1-1/2 minutes nor more than 1-1/2 hours. Concrete shall be rejected if not deposited within the time specified.
4. Admixtures:
  - a. Air entraining and chemical admixtures shall be charged into mixer as a solution and shall be dispensed by an automatic dispenser or similar metering device. Powdered admixtures shall be weighed or measured by volume as recommended by manufacturer. Accuracy of measurement of any admixture shall be within plus or minus 3%.
  - b. Two or more admixtures may be used in same concrete, provided such admixtures are added separately during batching sequence, and provided further that admixtures used in that combination retain full efficiency and have no deleterious effect on concrete or on properties of each other.
  - c. All admixtures are to be approved by Structural Engineer prior to commencing this work.
5. Retempering:

## SPECIFICATIONS

### GETTYSBURG ADDRESS MONUMENT AND PLAQUE INSTALLATION @ MOBILE NATIONAL CEMETERY AND BIVOUAC OF THE DEAD MONUMENT AND PLAQUE INSTALLATION @ BARRANCAS NATIONAL CEMETERY

#### MOBILE, ALABAMA AND PENSACOLA, FLORIDA

- a. Concrete shall be mixed only in quantities for immediate use. Concrete which has set shall be discarded, not retempered.
  - b. Indiscriminate addition of water to increase slump is prohibited.
  - c. When concrete arrives at project with slump below that suitable for placing, water may be added only if neither maximum permissible water-cement ratio nor maximum slump is exceeded. Water shall be incorporated by additional mixing equal to at least half of total mixing time required. Any addition of water above that permitted by limitation of water-cement ratio shall be accompanied by a quantity of cement sufficient to maintain proper water-cement ratio. Such additions shall only be used if approved by Architect. In any event, with or without addition of cement, not more than 2 gallons of water per cubic yard of concrete, over that specified in design mix, shall be added.
6. Cold Weather Batching: When temperature is below 40 degrees F or is likely to fall below 40 degrees F during 24 hour period after placing, provide adequate equipment for heating concrete materials. No frozen materials or materials containing ice shall be used. Temperatures of separate materials, including mixing water, when placed in mixer shall not exceed 100 degrees F. When placed in forms concrete shall have a temperature between 50 degrees F and 85 degrees F.
  7. Hot Weather Batching: Concrete deposited in hot weather shall have a placing temperature below 85 degrees F. If necessary, ingredients shall be cooled to accomplish this.

#### 2.3. FLOOR LEVELING AND FILL MATERIALS

- A. Epoxy Concrete Mortar: Floor leveling, non-shrink trowel applied epoxy concrete mortar; TPM 115 General Polymers Corp., A-H Emery Epoxy Topping #170 Anti-Hydro Corp., or approved equal, where areas to fill are less than 1/4 inch thick.

## SPECIFICATIONS

### GETTYSBURG ADDRESS MONUMENT AND PLAQUE INSTALLATION @ MOBILE NATIONAL CEMETERY AND BIVOUAC OF THE DEAD MONUMENT AND PLAQUE INSTALLATION @ BARRANCAS NATIONAL CEMETERY

MOBILE, ALABAMA AND PENSACOLA, FLORIDA

- B. Concrete Mortar: Floor leveling, patching and repair, non-shrink trowel applied concrete mortar; Master Builders EMBECO 411-A, Euclid EUCO, or approved equal, where areas of fill are greater than 1/4 inch thick.
- C. Cementitious Floor Leveling Material: Shall be self-leveling or trowelable with a minimum 28 day compressive strength of 3000 psi in accordance with ASTM C109. Material shall be equal to Quickrete No. 1249, Ardex V-800/K-55, Mapei "Ultra/Flex" or approved equal.

#### PART 3 - EXECUTION

##### 3.1. PLACEMENT

- A. Before any concrete is placed, the following items of work shall have been completed in the area of placing.
  - 1. Forms shall have been erected, adequately braced, cleaned, sealed, lubricated if required, and bulkheaded where placing is to stop.
  - 2. Any wood forms other than plywood shall be thoroughly water soaked before placing any concrete. The wetting of forms shall be started at least 12 hours before concreting.
  - 3. Reinforcing steel shall have been placed, tied and supported.
  - 4. Embedded work of all trades shall be in place in the forms and adequately tied and braced.
  - 5. The entire place of deposit shall have been cleaned of wood chips, sawdust, dirt, debris, hardened concrete and other foreign matter. No wooden ties or blocking shall be left in the concrete except where indicated for attachment of other work.
  - 6. Reinforcing steel, at the time the concrete is placed around it, shall be cleaned of scale, mill scale or other contaminants that will destroy or reduce bond.
  - 7. Concrete surfaces to which fresh concrete is to be bonded shall be brush cleaned to remove all dust and foreign matter and to expose the aggregate, and then coated with the bonding adhesive herein specified.

## SPECIFICATIONS

### GETTYSBURG ADDRESS MONUMENT AND PLAQUE INSTALLATION @ MOBILE NATIONAL CEMETERY AND BIVOUAC OF THE DEAD MONUMENT AND PLAQUE INSTALLATION @ BARRANCAS NATIONAL CEMETERY

#### MOBILE, ALABAMA AND PENSACOLA, FLORIDA

8. Prior to placing concrete for any slabs on grade, the moisture content of the subgrade below the slabs shall be adjusted to at least optimum moisture.
  9. No concrete shall be placed until Architect has observed formwork and reinforcement. Clean forms of all debris and remove standing water. Thoroughly clean reinforcement and all handling equipment for mixing and transporting concrete. Concrete shall not be placed against reinforcing steel that is hot to the touch. Notify Architect 48 hours in advance of concrete pour.
- B. Conveying: Handle concrete from mixer to place of final deposit by methods which will prevent separation or loss of ingredients. Deposit concrete in forms as nearly as practicable at its final position in a manner which will insure that required quality is obtained. Chutes shall slope not less than 4 inches and not more than 6 inches per foot of horizontal run.
- C. Depositing: Deposit concrete into forms in horizontal layers not exceeding 24 inches in thickness around building, proceeding along forms at a uniform rate and consolidating into previous pour. In no case shall concrete be poured into an accumulation of water ahead of pour, nor shall concrete be flowed along forms to its final place of deposit. Fresh concrete shall not be permitted to fall from a height greater than 6 feet without use of adjustable length pipes or, in narrow walls, of adjustable flexible hose sleeves. Concrete shall be scheduled so that placing is a continuous operation for the completion of each section between predetermined construction joints. If any concreting operation, once planned, cannot be carried on in a continuous operation, concreting shall stop at temporary bulkheads, located where resulting construction joints will least impair the strength of the structure. Location of construction joints shall be as shown on the drawings or as approved by Architect. The rate of rise in walls shall not be less than 2 feet per hour.
1. Consolidation: Concrete shall be thoroughly compacted and worked to all points with solid continuous contact to forms and reinforcement to eliminate air pockets and honeycombing. Power vibrators of approved type shall be used immediately following pour. Spading by hand, hammering of forms or other combination

## SPECIFICATIONS

### GETTYSBURG ADDRESS MONUMENT AND PLAQUE INSTALLATION @ MOBILE NATIONAL CEMETERY AND BIVOUAC OF THE DEAD MONUMENT AND PLAQUE INSTALLATION @ BARRANCAS NATIONAL CEMETERY

MOBILE, ALABAMA AND PENSACOLA, FLORIDA

- of methods will be allowed only where permitted by Structural Engineer. In no case shall vibrators be placed against reinforcing steel or used for extensive shifting of deposited fresh concrete. Provide and maintain standby vibrators, ready for immediate use.
2. Hot Weather Concreting: Unless otherwise directed by the Architect, perform all work in accordance with ACI 305 when air temperature rises above 75 degrees F and the following:
    - a. Mixing Water: Keep water temperature as low as necessary to provide for the required concrete temperature at time of placing. Ice may be required to provide for the design temperature.
    - b. Aggregate: Keep aggregate piles continuously moist by sprinkling with water.
    - c. Temperature of Concrete: The temperature of the concrete mix at the time it is being placed in the forms shall not exceed 85 degrees F. The method employed to provide this temperature shall in no way alter or endanger the design mix or the design strength required.
    - d. Dampen subgrade and formwork before placing concrete. Remove all excess water before placing concrete. Keep concrete continuously wet when air temperature exceeds 85 degrees F for a minimum of 48 hours after placing concrete.
    - e. Protection: Minimize evaporation from concrete in place by providing shade and windbreaks. Maintain such protection in place for 14 days minimum.
  3. Cold Weather Concreting: Follow recommended ACI 306 procedures when air temperature falls below 40 degrees F., as approved by Architect. Concrete placed in freezing temperatures shall have a temperature of not less than 50 degrees F. Maintain this temperature for at least 7 days. No chemicals or salts shall be used to prevent freezing and no accelerating agents shall be used without prior approval from Architect.

## SPECIFICATIONS

### GETTYSBURG ADDRESS MONUMENT AND PLAQUE INSTALLATION @ MOBILE NATIONAL CEMETERY AND BIVOUAC OF THE DEAD MONUMENT AND PLAQUE INSTALLATION @ BARRANCAS NATIONAL CEMETERY

MOBILE, ALABAMA AND PENSACOLA, FLORIDA

- D. Construction Joints: Install only as indicated and noted on Drawings. Joints not indicated on Drawings shall be so located, when approved, as to least impair strength of structure, and shall conform to typical details. Construction joints shall have level tops, vertical sides. Horizontal construction joints shall be thoroughly cleaned and roughened by removing entire surface film and exposing clean aggregate solidly embedded in mortar matrix. Joints between concrete and masonry shall be considered construction joints. Vertical construction joints need not be roughened. See Drawings for doweling and required keys.
1. Roughen construction joints by any of following methods:
    - a. By sandblasting joint.
    - b. By thoroughly washing joint, using a high pressure hose, after concrete has taken initial set. Washing shall be done not less than 2 hours nor more than 4 hours after concrete has been poured, depending upon setting time.
    - c. By chipping and wire brushing.
  2. All decisions pertaining to adequacy of construction joint surfaces and to compliance with requirements pertaining to construction joints shall rest exclusively with Structural Engineer.
  3. Just before starting new pour, horizontal and vertical joint surfaces shall be dampened (but not saturated).
  4. Before placing regular concrete mix, horizontal construction joint surfaces shall be covered with a layer of mortar composed of cement and fine aggregate of same proportions as that used in prescribed mix, but omitting coarse aggregate.
- E. Concrete Slabs on Grade:
1. Exterior concrete slabs on grade shall be poured as required under this Section. Base shall be accurately leveled and compacted prior to placing of concrete.
  2. Typically, interior slabs on grade shall be poured over a vapor barrier and over a minimum of four (4 inch) inches, unless otherwise indicated, of compacted crushed rock.
  3. If sand is indicated on the structural drawings, place over the vapor retarder, otherwise, provide no sand layer.

## SPECIFICATIONS

### GETTYSBURG ADDRESS MONUMENT AND PLAQUE INSTALLATION @ MOBILE NATIONAL CEMETERY AND BIVOUAC OF THE DEAD MONUMENT AND PLAQUE INSTALLATION @ BARRANCAS NATIONAL CEMETERY

MOBILE, ALABAMA AND PENSACOLA, FLORIDA

4. Vapor Retarder installation shall be in accordance with manufacturer's instructions and ASTM E 1643-98.
  - a. Unroll Vapor Retarder with the longest dimension parallel with the direction of the pour.
  - b. Lap Vapor Retarder over footings and seal to foundation walls.
  - c. Overlap joints 6 inches and seal with specified tape.
  - d. Seal all penetrations (including pipes) per manufacturer's instructions.
  - e. No penetration of the Vapor Retarder is allowed except for reinforcing steel and permanent utilities.
  - f. Repair damaged areas by cutting patches of Vapor Retarder, overlapping damaged area 6 inches and taping all four sides with tape.
  
- F. Control Jointing - Slabs on Grade:
  1. Joints shall be in locations indicated on Drawings, or as directed by Architect.
  2. Joints in interior slabs shall be made by one of following methods:
    - a. By use of construction joints laid out in checkerboard pattern; pour and allow alternate slabs to set; fill out balance of checkerboard pattern with second pour.
    - b. By use of dummy groove joints at least 1/4 depth of slab, and at least 1/8 inch wide. These joints may be sawcut as soon as wet concrete can support the weight of the equipment and operator. Delaying sawcutting past this point will make jointing ineffective.
  3. Control jointing in exterior paving slabs shall be poured in a checkerboard pattern as described above, but with joint edges tooled to provide a uniform joint at least 3/8 inch in depth.
  4. Slab reinforcing need not be terminated at control joints.
  5. Construction and expansion joints shall be counted as control joints.
  
- G. Expansion Joints - Slabs on Grade:
  1. Unless otherwise indicated, use 3/8 inch thick expansion joint filler.  
See Section 2.01 H

## SPECIFICATIONS

### GETTYSBURG ADDRESS MONUMENT AND PLAQUE INSTALLATION @ MOBILE NATIONAL CEMETERY AND BIVOUAC OF THE DEAD MONUMENT AND PLAQUE INSTALLATION @ BARRANCAS NATIONAL CEMETERY

#### MOBILE, ALABAMA AND PENSACOLA, FLORIDA

2. Joints in interior slabs on grade shall be in locations indicated, or, where not indicated, locate joints at uniformly spaced intervals not exceeding 100 feet.
  3. Joints in exterior slabs on grade shall be installed at each side of structures, at curb transitions opposite apron joints, at ends of curb returns, at back of curb when adjacent to sidewalk, and at uniformly spaced intervals not exceeding 20 feet.
  4. Edges of concrete at joints shall be edger finished to approximately 3/8 inch radius.
  5. Interrupt reinforcing at all expansion joints.
- H. Score markings on exterior slabs on grade shall be located as indicated. Where not indicated, mark slabs into rectangles of not less than 12 square feet nor more than 20 square feet using a scoring tool which will leave edges of score markings rounded.

#### 3.2. CURING AND PROTECTION

- A. Curing: Exposed surfaces of all concrete used in structure shall be maintained in a moist condition for at least 7 days after placing. The following final curing processes shall normally be considered to accomplish this. Concrete shall be maintained at not less than 50 degrees F nor more than 100 degrees F for a period of 72 hours after being deposited.
1. Initial Curing Process - Flat Work:
    - a. Mist Spraying: As soon as troweling of concrete surfaces is completed, exposed concrete shall be sprayed continuously with a special atomizer spray nozzle, capable of producing a fine mist. Spraying shall be done without any dripping of water from nozzle. Amount of spraying shall be such as to maintain surface of concrete moist without any water accumulating on surface. Maintain spraying for a minimum of 12 hours, or until such time as hereinafter described curing process is applied. Mist spraying will not normally be required when the ambient air temperature is below 90 degrees F.



## SPECIFICATIONS

### GETTYSBURG ADDRESS MONUMENT AND PLAQUE INSTALLATION @ MOBILE NATIONAL CEMETERY AND BIVOUAC OF THE DEAD MONUMENT AND PLAQUE INSTALLATION @ BARRANCAS NATIONAL CEMETERY

MOBILE, ALABAMA AND PENSACOLA, FLORIDA

2. Final Curing Process - Flatwork: Except as noted, use any of following:
  - a. Water Curing: Concrete shall be kept wet by mechanical sprinklers or by any other approved method which will keep surfaces continuously wet.
  - b. Saturated Burlap Curing: Finished surfaces shall be covered with a minimum of two layers of heavy burlap which shall be kept saturated during the curing period.
  - c. Curing Compounds: Apply a water based curing compound as indicated in Materials. Membrane curing compounds of chlorinated rubber or resin type conforming to ASTM C309 may be used only if specifically approved by Architect. Use of membrane curing compound will not be permitted on surfaces to be painted, or to receive ceramic tile, membrane waterproofing or hardeners and sealers. Membrane curing compound may be used in areas to receive resilient floor tile, provided it is wax-free, compatible with adhesive used and approved by adhesive manufacturer. Agitate curing compounds thoroughly by mechanical means continuously during use and spray or brush uniformly in accordance with manufacturer's recommendations. Apply immediately following final finishing operation. All curing compounds shall conform to State Air Resources Board VOC Regulations.
  - d. Waterproof paper conforming to ASTM C 171, or opaque polyethylene film, may be used. Concrete shall be covered immediately following final finishing operation. Anchor paper or film securely and seal all edges in such a manner as to prevent moisture escaping from concrete.
3. Curing Process - Formed Surfaces: Forms heated by sun shall be kept moist during curing period. If forms are to be removed during curing period, curing as described for flatwork shall be commenced immediately.

## SPECIFICATIONS

### GETTYSBURG ADDRESS MONUMENT AND PLAQUE INSTALLATION @ MOBILE NATIONAL CEMETERY AND BIVOUAC OF THE DEAD MONUMENT AND PLAQUE INSTALLATION @ BARRANCAS NATIONAL CEMETERY

#### MOBILE, ALABAMA AND PENSACOLA, FLORIDA

- B. Refer to Drawings for areas of concrete slab not to receive curing compounds or hardening compounds. Where concrete floors are to receive heavy duty coatings, waterproof coatings and the like, verify with coating installer the type of finish required for specified coating.
- C. Protection: Contractor shall be responsible for protection of finished concrete against injury by rain, cold, vibration, animal tracks, marking by visitors, vandalism, etc.
- D. Provide additional curing agents or compounds, not necessarily listed herein, but as recommended and or required for use with shake type hardeners or other special coatings and coverings by their manufacturers for a complete and proper installation.

#### 3.3. FINISHES

- A. Formed Surfaces:
  - 1. Rough Form Finish: Surfaces shall be reasonably true to line and plane with no specified requirements for selected facing materials. Tie holes and defects shall be patched and fins exceeding 1/4 inch in height shall be rubbed down with wooden blocks. Fins and other rough spots at surfaces to receive membrane waterproofing shall be completely removed and the surfaces rubbed smooth. Otherwise, surfaces shall be left with the texture imparted by forms.
    - a. Rough finish shall be used for the following areas:
      - 1) 12" Below finished grade and deeper and unexposed surfaces.
  - 2. Smooth Plywood Form Finish: Finish shall be true to line and plane. Tie holes and defects shall have been patched and ground with surface fins removed. Arrangement of plywood sheets shall be orderly, symmetrical, as large as practical and free of torn grain or worn edges. Surface concrete shall be treated with 1 part muriatic acid, in three parts water solution, followed immediately by a thorough rinsing with clear water. Surfaces which are glazed, have efflorescence, or traces of form oil, curing compounds or

## SPECIFICATIONS

### GETTYSBURG ADDRESS MONUMENT AND PLAQUE INSTALLATION @ MOBILE NATIONAL CEMETERY AND BIVOUAC OF THE DEAD MONUMENT AND PLAQUE INSTALLATION @ BARRANCAS NATIONAL CEMETERY

#### MOBILE, ALABAMA AND PENSACOLA, FLORIDA

parting compounds shall be cleaned or treated to match other formed surfaces, except as otherwise indicated or specified.

- a. Smooth Plywood Form Finish shall be used for the following areas:
    - 1) All surfaces from 12" below grade and above unless otherwise specified.
  3. Smooth Plastic Liner Finish: Surface shall be smooth, concrete free of honeycombing, air pockets larger than 1/8 inch in diameter, and fins. a. This finish shall be used only where indicated on the Drawings.
- B. Flatwork:
1. Unless otherwise indicated or specified, flatwork shall have an integral monolithic finish.
  2. Integral Monolithic Finish: Apply as soon as freshly poured concrete slabs will bear weight of workers. Pour slabs full thickness to finish floor elevations indicated. At proper time, tamp surface repeatedly with a wire mesh or grid tamper in a manner to force aggregate down below surface and to bring sufficient mortar to surface to provide for a smooth coating of cement mortar over entire surface. Allow surface mortar to partially set, then float with wooden floats and finish with one of following, as required.
    - a. Broom Finish: Steel trowel surface to a smooth dense surface free of lines, tool marks, cat faces and other imperfections. After troweling, and before final set, give surface a broom finish, brushing in direction noted on Drawings, or as directed. Broom finish shall be used typically on exterior flatwork except as otherwise indicated or specified and shall be "medium" texture as approved by Architect.
    - b. Smooth Steel Trowel Finish: Apply 2 steel trowelings to obtain hard, smooth surface. All lips, irregularities, uneven levels, etc. shall be worked out before last troweling. All interior flatwork shall have a smooth steel trowel finish unless specified otherwise. Provide a Dry

## SPECIFICATIONS

### GETTYSBURG ADDRESS MONUMENT AND PLAQUE INSTALLATION @ MOBILE NATIONAL CEMETERY AND BIVOUAC OF THE DEAD MONUMENT AND PLAQUE INSTALLATION @ BARRANCAS NATIONAL CEMETERY

MOBILE, ALABAMA AND PENSACOLA, FLORIDA

Shake Floor Hardener at all exposed interior slabs including slabs on metal deck.

3. Tolerances:
  - a. For tolerances not indicated, refer to ACI 117.
  - b. Finished surfaces of all interior integral finished flatwork shall be sufficiently even to contact a 10' long straightedge with a tolerance of 1/8 inch.
  - c. Finished surfaces of exterior integral finished flatwork shall not vary more than 1/4 inch from a 10' long straightedge, except at grade changes.
  
- C. Sacked Surfaces: Exposed surfaces that are unacceptable in appearance to the Architect shall be sacked.
  1. Prepare concrete surfaces in accordance with the referenced standards. Remove any form release materials by stoning by hand, power grinding or other method approved by the Architect.
  2. Prepare concrete surfaces to receive sack finishing with a light sand blasting.
  3. For best results, grout application and rubbing should be performed when areas to be treated are shaded and during cool, damp weather. When work is to be performed in hot and dry weather, a fog spray should be available for continuous use.
  4. Prepare grout samples for matching of concrete surfaces for approval by the Architect. These shall be made in the following proportions of gray cement to white cement to sand: 1:1:2, 1:2:3, and 2:1:3, etc. until the correct matching color is obtained on the test areas. Sand should be fine enough to pass the Number 30 sieve. Mixes should be made to a good workable consistency in a clean container and the mix with the best color chosen, or modified if needed.
  5. Provide sufficient quantities of sand and cement from the same source for the complete work at the job site.
  6. Mixing and Application:
    - a. Mixing of grout on the job should be timed for it to be used up within 1 to 1-1/2 hours.

## SPECIFICATIONS

### GETTYSBURG ADDRESS MONUMENT AND PLAQUE INSTALLATION @ MOBILE NATIONAL CEMETERY AND BIVOUAC OF THE DEAD MONUMENT AND PLAQUE INSTALLATION @ BARRANCAS NATIONAL CEMETERY

#### MOBILE, ALABAMA AND PENSACOLA, FLORIDA

- b. Let the grout stand 20 to 30 minutes after mixing, and then remixed before applying.
  - c. Soak the concrete surface thoroughly with water at least 15 minutes before applying grout and again just before application so that the surface is adequately wet during the operation.
  - d. Apply grout with plasterer's trowel or sponge rubber float in sweeping strokes from the bottom up. Brush or spray gun applications may be used when approved by the Architect.
  - e. Work in freshly applied grout vigorously with a sponge rubber float, then let sit until some of its plasticity is gone but not until it loses its damp appearance. At this point it shall be rubbed with clean, dry burlap to remove the excess grout, leaving no visible film on the surface but filling all air holes.
  - f. Keep the surface wet for a day after grouting and sack rubbing are completed.
7. Alternate methods of application and materials shall be subject to the approval of the Architect.

#### 3.4. PATCHING

- A. Formed Surfaces:
  1. Promptly upon removal of contact forms and after concrete surfaces have been inspected, form ties shall be removed and all necessary patching and pointing shall be expertly done.
  2. Honeycombed areas shall be removed down to sound concrete, coated with a bonding grout or approved compound and patched using a low shrinkage high bond mortar. Patched areas shall be cured by being kept damp for at least 5 days.
  3. Tie holes shall be cleaned, dampened and filled solid with patching mortar or cement plugs of an approved variety.
- B. Slabs on Grade: After entire slab is finished, shrinkage cracks that may appear shall be patched as follows:

## SPECIFICATIONS

### GETTYSBURG ADDRESS MONUMENT AND PLAQUE INSTALLATION @ MOBILE NATIONAL CEMETERY AND BIVOUAC OF THE DEAD MONUMENT AND PLAQUE INSTALLATION @ BARRANCAS NATIONAL CEMETERY

#### MOBILE, ALABAMA AND PENSACOLA, FLORIDA

1. Where slab is not exposed or where appearance is not important, cracks larger than 1/32 inch wide shall be filled with cement grout and struck off level with surface.
2. Where slab is exposed and appearance is important, unsightly cracks shall be repaired in a manner satisfactory in appearance to Architect. If this cannot be accomplished, concrete shall be considered defective.

#### 3.5. DEFECTIVE CONCRETE

- A. Defective concrete shall mean any of the following:
  1. Concrete not meeting 100 percent of the specified 28 day compressive strength.
  2. Concrete exhibiting rock pockets, voids, spalls, streaks, cracks, exposed reinforcing to extent that strength, durability, or appearance is adversely affected.
  3. Concrete significantly out of place, line, or level.
  4. Concrete not containing the required embedded items.
- B. Upon determination that concrete strength is defective:
  1. Should cylinder tests fall below minimum strength specified, concrete mix for remainder of work shall be adjusted to produce required strength. Core samples shall be taken and tested from cast-in-place concrete where cylinders and samples indicate inferior concrete with less than minimum specified strength.
    - a. Cores of hardened concrete shall be taken and tested in accordance with ASTM C 42 and C 39. Number and location of such cores shall be subject to the approval of Architect.
    - b. Cost of core sampling and testing will be paid for by the Contractor.
    - c. "500 psi" and "85 percent" reduction in IBC Section 1905.6.5 will not justify low cylinder tests.
- C. Upon determining that concrete surface is defective, Contractor may restore concrete to acceptable condition by cutting, chipping, pointing, patching, grinding, if this can be done without significantly altering strength of structure. Permission to patch defective areas will not be

## SPECIFICATIONS

### GETTYSBURG ADDRESS MONUMENT AND PLAQUE INSTALLATION @ MOBILE NATIONAL CEMETERY AND BIVOUAC OF THE DEAD MONUMENT AND PLAQUE INSTALLATION @ BARRANCAS NATIONAL CEMETERY

MOBILE, ALABAMA AND PENSACOLA, FLORIDA

considered a waiver of the right to require removal if patching does not, in the opinion of the Architect, satisfactorily restore quality and appearance.

- D. If core tests indicate that concrete is below the strength specified, or if patching does not restore concrete to specified quality and appearance, the concrete shall be deemed defective, and shall be removed and replaced without additional cost to the Owner.
  - E. No repair work shall begin until procedure has been reviewed by the Architect and Structural Engineer.
- 3.6. SURFACE HARDENER AND SEALER

- A. Seal all exposed flatwork (receiving no other finish product) with clear sealer, except surfaces receiving ceramic tile, quarry tile, poured flooring or other special finishes specified, or as scheduled on the Drawings.
  - 1. Apply sealer in 2 or 3 coats, in accordance with manufacturer's directions, using the maximum quantity recommended.
    - a. Concrete floors must be thoroughly cured for a minimum of 30 days and completely dry before treatment.
    - b. Surfaces to be treated must be clean, free of membrane curing compounds, dust, oil, grease and other foreign matter.
    - c. Upon completion, concrete surfaces shall be clean and without discoloration or traces of excess sealer left on the surface.
- B. Apply a dry shake hardener at all exposed flatwork slabs (receiving no other finish product) as scheduled or indicated in the Drawings. Apply in accordance with the manufacturer's favorably reviewed application instructions and recommendations. A spray-able sealer/hardener may be used at utility areas not normally accessible to the public.

3.7. GROUTING

## SPECIFICATIONS

### GETTYSBURG ADDRESS MONUMENT AND PLAQUE INSTALLATION @ MOBILE NATIONAL CEMETERY AND BIVOUAC OF THE DEAD MONUMENT AND PLAQUE INSTALLATION @ BARRANCAS NATIONAL CEMETERY

MOBILE, ALABAMA AND PENSACOLA, FLORIDA

- A. Prepare and place grout materials at locations as indicated on the Drawings in accordance with the manufacturer's recommendations and installation instructions.
  - B. Pack grout materials solidly between bearing surfaces and bases or plates as indicated and to ensure no voids.
- 3.8. ADJUSTING AND CLEANING
- A. Remove all debris, excess materials, tools and equipment resulting from or used in this operation at completion of this work.

END OF SECTION



SECTION 03450  
PLANT-PRECAST ARCHITECTURAL CONCRETE

PART 1 - GENERAL

1.1. SECTION INCLUDES

1. Architectural precast concrete memorials; with supports, anchors, and attachments; perimeter and intermediate joint seals; and grouting under units.

1.2. RELATED SECTIONS

- A. Section 03300 - Cast-in-Place Concrete: Memorial foundation.
- B. Section 07920 - Joint Sealants: Perimeter joints with sealant and backing.

1.3. REFERENCES

- A. ACI 301 - Specifications for Structural Concrete for Buildings.
- B. ACI 318 - Building Code Requirements for Reinforced Concrete.
- C. ACI 523 - Guide for Low Density Precast Concrete.
- D. ASTM A 36/A36M - Carbon Structural Steel.
- E. ASTM A 123 - Zinc (Hot-Dipped Galvanized) Coatings on Iron and Steel Products.
- F. ASTM A 185 - Steel Welded Wire, Fabric, Plain, for Concrete Reinforcement.
- G. ASTM A 307 - Carbon Steel Bolts and Studs, 60,000 Pounds per square inch Tensile Strength.
- H. ASTM A 325/A325 - High Strength Bolts for Structural Steel Joints.
- I. ASTM A 767/A767M - Zinc-Coated (Galvanized) Bars for Concrete Reinforcement.
- J. ASTM A 775/A775M - Epoxy Coated Reinforcement Steel Bars.
- K. ASTM C 31 - Making and Curing Concrete Test Specimens in the Field.
- L. ASTM C 33 - Concrete Aggregates.

03450-1

Plant-Precast Architectural Concrete

- M. ASTM C 150 - Portland Cement.
  - N. ASTM C 260 - Air-Entraining Admixtures for Concrete.
  - O. ASTM C 330 - Lightweight Aggregates for Structural Concrete.
  - P. AWS D1.1 - Structural Welding Code.
  - Q. AWS D1 .4 - Structural Welding Code, Reinforcing Steel.
  - R. PCI MNL-117 - Manual for Quality Control for Plants and Production of Architectural Precast Concrete Products.
  - S. PCI MNL-120 - Design Handbook - Precast and Prestressed Concrete.
  - T. PCI MNL-122 - Architectural Precast Concrete.
  - U. PCI MNL-123 - Manual on Design of Connections for Precast Prestressed Concrete.
- 1.4. DESIGN REQUIREMENTS
- A. Design units to withstand actual loads such as wind, suction, deflection, and thermal movement loads.
  - B. Design and size components to withstand seismic loads and sway displacement as calculated in accordance with Uniform Building Code (UBC).
  - C. Design units to accommodate construction tolerances, deflection of columbarium unit members, and clearances of intended openings.
  - D. Design component connections to accommodate structure movement and thermal movement. Provide adjustment to accommodate misalignment of structure without unit distortion or damage.
- 1.5. SUBMITTALS
- A. Shop Drawings: Indicate layout, unit locations, configuration, unit identification marks, reinforcement, connection details, support items, location of lifting devices, dimensions, openings, and relationship to adjacent materials. Provide erection drawings.
  - B. Design Data: Submit design data reports indicating calculations for loadings and stresses of fabricated, designed framing and connections.

- C. Samples: Submit two panels, 24 -inches by 24 -inches in size illustrating surface finish, color, and texture.
  - D. Operation and Maintenance Data: Procedures for Project closeout submittals. Indicate surface cleaning instructions.
- 1.6. QUALITY ASSURANCE
- A. Perform Work in accordance with PCI MNL-1 17, PCI MNL-120, PCI MNL-122, PCI MNL-123, and ACI 318.
  - B. Welding: AWS D1.1 and AWS D1.4.
  - C. Fabricator Qualifications: Company specializing in performing Work of this section with minimum ten years documented experience with sufficient production capacity to produce and deliver required units without causing delay in Work.
    - 1. Fabricating plant shall be certified by one of the following:
      - a. Architectural Precast Association (APA)
      - b. Precast/Prestressed Concrete Institute (PCI), Group A1.
      - c. Or equal certification program
  - D. Installer Qualifications: Installer shall have a record of at least ten years of documented experience with sufficient installation capacity to install required units without causing delay in Work.
  - E. Design units under direct supervision of a professional engineer experienced in design of this Work and licensed at the place where the Project is located.
  - F. Welder Qualifications: Qualified within previous 12 months in accordance with AWS D1.1 and AWS D1.4.
- 1.7. DELIVERY, STORAGE, AND HANDLING
- A. Handle precast units to position, consistent with their shape and design. Lift and support only from support points.
  - B. Blocking and Lateral Support During Transport and Storage: Clean, non-staining, without causing harm to exposed surfaces. Provide temporary lateral support to prevent bowing and warping.
  - C. Protect units to prevent staining, chipping, or spalling of concrete.
  - D. Mark units with date of production in location not visible to view when in final position in structure.

## PART 2 - PRODUCTS

### 2.1. MATERIALS

#### A. Concrete Materials:

1. Portland Cement: Complying with ASTM C 150, Type I or III, white or gray colors to achieve desired finish colors. Use only one brand, type, and color from the same mill. Gray cement may be used for non-exposed backup mixes.
2. Aggregates: Complying with ASTM C 33, gradation may differ to achieve desired finish characteristics. Select coarse and fine aggregate colors and screen sizes to match approved sample(s). Verify that adequate supply, from one pit or quarry, for each type of aggregate is available for the entire Project. If possible obtain entire aggregate supply prior to starting Work, or have aggregate supply held in reserve by aggregate supplier.
3. Lightweight aggregate: Complying with ASTM C 330.
4. Water: Potable. Clean, clear, and free from deleterious amounts of salts, acids, alkalies, organic materials, oils, detergents, or other matter that may interfere with color, curing, or strength of concrete.
5. Admixtures: Select to be compatible in specified mix.
  - a. Air Entraining: Complying with ASTM C 260.
  - b. Water Reducing: Complying with ASTM C 494, Type A, B, C, F or G.
  - c. Silica Fume: Complying with ASTM C 1240, for cement replacement for high performance concrete.
  - d. Coloring Agent: Complying with ASTM C 979, compatible with other concrete materials.
  - e. Other constituents: Integral water repellents and other chemicals for which no ASTM standard exists, shall be previously established as suitable for use in concrete or shall be shown by test or experience not to be detrimental to the concrete.

#### B. Formwork:

1. Provide forms with acceptable form facing materials that are non-reactive with concrete or form release agents and will produce required finish surfaces.
2. Construct and maintain forms to produce precast concrete units of shapes, lines, and dimensions indicated, within specified tolerances.

- C. Reinforcing Materials:
1. Reinforcing Bars: Complying with ASTM A 615/A 615M, Grade 40 or 60, unless otherwise required to meet structural requirements.
  2. Galvanized Reinforcing Bars: Complying with ASTM A 767/A 767M, hot-dip galvanized; use where concrete cover is less than 1-1/2 inches.
  3. Epoxy Coated Reinforcing Bars: Complying with ASTM A 934; use in special applications where indicated.
  4. Steel Welded Wire Fabric: Complying with ASTM A 185, plain, cold drawn.
- D. Connection Materials:
1. Steel Shapes and Plates: Complying with ASTM A 36/A 36M.
  2. Malleable Iron Castings: Complying with ASTM A 47/A 47M.
  3. Carbon Steel Plates: Complying with ASTM A 283/A 283M.
  4. High Strength, Low Alloy Structural Steel: Complying with ASTM A 572.
  5. Carbon Steel Structural Tubing: Complying with ASTM A 500, Grade B.
  6. Anchor Bolts: Complying with ASTM A 307, carbon steel or ASTM A 325 (ASTM A 325M), high strength; bolts, nuts, and washers.
  7. Welded Headed Studs: Complying with AWS D1.1/D1.3M, Type B.
  8. Deformed Steel Wire Bar Anchors: Complying with ASTM A 496.
  9. Stainless Steel Plate exposed to weather in final assembly: Complying with ASTM F 593, Type 304 or Type 316; bolts and studs, nuts and washers.
  10. Finish for Steel Connection Materials:
    - a. Hot-dip galvanize steel exposed to weather in final assembly complying with ASTM A 123/A 123M or ASTM A 153/A 153M.
    - b. Shop Prime Remaining Steel Shapes: Complying with SSPC Paint 25.
    - c. Anchor Bolts, Nuts, Washers, Cadmium Plated: Complying with ASTM A 563, Grade C.
    - d. Hot-dip galvanize setting bolts or projecting steel in masonry applications complying with ASTM A 153/A 153M.
    - e. Galvanizing Repair Paint: Complying with DOD P-21035A or SSPC Paint 20.
    - f. Welding Electrodes: Comply with AWS Standards.

- E. Bearing Pads:
  - 1. Elastomeric pads, complying with ASTM D 412.
  - 2. High density plastic, 1/8-inch thick, smooth both sides.
- F. Grout Materials:
  - 1. Cement Grout: Cement complying with ASTM C 150; sand complying with ASTM C 404; proportions 1:2.5 by volume, minimum water for placement and hydration.
  - 2. Non-Shrink Grout: Complying with ASTM C 1107.
  - 3. Epoxy Grout: Consult Suppliers.

## 2.2. MIXES

- A. Design mixes for each type of concrete specified shall be prepared by an independent testing agency or by an architectural precast manufacturing plant at precast manufacturer's option.
- B. Proportion mixes by either testing agency trial batch or field test data methods in accordance with ACI 211.1, using materials to be used on the Project, to provide concrete with properties as follows:
  - 1. Concrete Density: Normal weight.
  - 2. Compressive Strength: 5,000 psi (35 MPa) when tested in accordance with ASTM C 39/C 39M.
  - 3. Maximum water cement ratio 0.40 at point of placement.
  - 4. Add air-entrainment admixture to result in air content at point of placement complying with ACI 533R requirements (5 to 7 percent).
  - 5. Water absorption maximum 6% (by weight) when tested in accordance with ASTM C642
- C. Sealant: Type specified in Section 07920.

## 2.3. FABRICATION

- A. General:
  - 1. Fabricate precast concrete units with manufacturing and testing procedures, quality control recommendations, and dimensional tolerances as specified in PCI MNL-117 or ACI 533R, unless more stringent requirements are shown or specified.
  - 2. Fabricate units straight, smooth and true to size and shape, with exposed edges and corners precise and square, unless otherwise indicated.
- B. Use rigid molds, constructed to maintain precast unit uniform in shape, size, and finish.

- C. Cast openings larger than 10 inches (254 mm) in any dimension according to locations shown on Shop Drawings. Smaller holes may be field cut when approved by Architect.
- D. Reinforcement: Comply with CRSI Manual of Standard Practice, PCI MNL-1 17, or ACI 533R recommendations. Reinforce architectural precast concrete units to resist handling, transportation, and erection stresses, and to comply with specified performance criteria.
- E. Cast-in Items: Provide embedded anchors, inserts, steel shapes, and lifting devices as shown on reviewed Shop Drawings. Firmly hold cast items in place by jigs, strongbacks, or other approved means.
  - 1. Units with cast-in place plumbing shall have stubbed ends capped and sealed four inches beyond edge of concrete footing. Threaded end of plumbing to had threaded plug installed. Cap and plug to remain in place until final plumbing connections are to be made. Coordinate with Sections 15400 – Plumbing Systems and 15440 Plumbing Fixtures
- F. Locate hoisting devices to permit removal after erection.
- G. Comply with PCI MNL-1 17 or ACI 533R requirements for measuring, mixing, transporting, and placing concrete. Place facing mix to a thickness of the greater of 1 inch (26 mm) or 1.5 times the maximum aggregate size. Place back-up concrete to ensure bond with face concrete.
- H. Consolidate concrete using equipment and procedures complying with PCI MNL117 or ACI 533R.
- I. Permanently mark units with pick-up points as shown on reviewed Shop Drawings. Imprint casting date and piece mark on a surface to be concealed from view in the finished structure. Imprint should be flush with finished surface without any surface deformation with no raised or embossed effects.
- J. Cure concrete in accordance with PCI MNL-1 17 or ACI 533R requirements to develop concrete quality, and to minimize appearance blemishes such as non-uniformity, staining, or surface cracking.
- K. Discard units that are warped, cracked, broken, spalled, stained, or otherwise defective. Minor patching in plant is acceptable, providing structural adequacy and appearance of units is not impaired or patched area is ultimately concealed by other in-place work.

- L. Manufacturing Tolerances: Fabricate to tolerances listed in PCI MNL-1 17 or ACI 533R.
  - M. Maintain plant records and quality control program during production of precast units. Make records available upon request.
  - N. Maintain consistent quality during manufacture.
  - O. Fabricate connecting devices, plates, angles, items fit to steel framing members, inserts, bolts, and accessories. Fabricate to permit initial placement and final attachment.
  - P. Weld steel fabrications in accordance with AWS D1.1. Weld reinforcing steel in accordance with AWS D1 .4. Do not tack weld reinforcing.
- 2.4. FINISH - PRECAST UNITS
- A. Finish Type A: Ensure exposed-to-view finish surfaces of precast units are uniform in color and have smooth cut stone appearance. Smooth surface finish free from pockets, sand streaks, honeycomb, with uniform color and texture. Bugholes are not permitted. Precast to match Samples provided for Columbarium Project.
  - B. Finish Exposed Back Surface of Units:
    - 1. To match face surface of units.
  - C. Finish unexposed surfaces of units by steel trowel finish.
- 2.5. FINISH - SUPPORT DEVICES
- A. Clean surfaces of rust, scale, grease, and foreign matter.
  - B. Galvanize after fabrication to 2 ounces per square foot in accordance with ASTM A 123.
- 2.6. FABRICATION TOLERANCES
- A. Maximum Out of Square: 1/8-inch in 10 feet, noncumulative.
  - B. Variation from Dimensions Indicated on shop drawings: Plus or minus 1/8-inch.
  - C. Maximum Misalignment of Anchors, Inserts, Openings: 1/8-inch.
  - D. Maximum Bowing of Units: Length of bow, 360.
- 2.7. SOURCE QUALITY CONTROL AND TESTS



- A. Provide testing and analysis of concrete mix.
- B. Take three concrete test cylinders for every ten cubic yards of concrete placed in accordance with ASTM C 31.
- C. Take two slump tests for every six test cylinders in accordance with ASTM C 143.
- D. Take one air entrainment test cylinders for each set of exterior concrete test cylinders taken.
- E. Take water absorption test in accordance with PCI MNL-1 17.

### PART 3 - EXECUTION

#### 3.1. EXAMINATION

- A. Verify that building structure, anchors, devices, and openings are ready to receive work of this Section.

#### 3.2. PREPARATION

- A. Provide for erection procedures and induced loads during erection. Maintain temporary bracing in place until final support is provided.

#### 3.3. ERECTION

- A. Erect units without damage to shape or finish. Replace or repair damaged panels.
- B. Erect units level and plumb within allowable tolerances.
- C. Align and maintain uniform horizontal and vertical joints as erection progresses.
- D. When units require adjustment beyond design or tolerance criteria, discontinue affected work; advise Contracting Officer's Technical Representative.
- E. Fasten and Weld units in place. Perform welding in accordance with AWS D1.1.
- F. Touch-up field welds and scratched or damaged galvanized surfaces.
- G. Weld reinforcing steel in accordance with AWS D1 .4. Do not tack weld reinforcing.

- H. Set vertical units dry, without grout, attaining joint dimension with lead or plastic spacers. Pack grout to base of unit.
  - I. Exposed Joint Dimension: 1/2-inch.
  - J. Where two stage joint seal is required, sequence with sealant application to ensure that sealant, gaskets, and similar items required for interior side seal are installed concurrently with installation of precast units.
  - K. Seal perimeter and intermediate joints in accordance with Section 07920 with sealant noted under 'Building Sealants.'
- 3.4. ERECTION TOLERANCES
- A. Maximum Variation from Plane of Location: 1/4-inch in 10 feet and 3/8-inch in 100 feet, noncumulative.
  - B. Maximum Offset from True Alignment Between Two Connecting Units: 1/8-inch.
  - C. Joint Tolerance: Plus or minus 1/4-inch.
- 3.5. ADJUSTING
- A. Adjust units so that joint dimensions are within tolerances.
- 3.6. CLEANING
- A. Clean exposed surfaces of units after erection if soiled or stained.
    - 1. Wash and rinse according to architectural precast concrete manufacturer's recommendations. Protect other work from damage while cleaning.
    - 2. Do not use cleaning materials or methods that change the appearance of architectural precast concrete finishes. Test clean a small area to verify adequacy and safety of materials and methods.
    - 3. Apply water repellents specified in Section 07190 – Water Repellants
- 3.7. PROTECTION OF INSTALLED CONSTRUCTION
- A. Provide non-combustible shields during welding operations.

END OF SECTION

03450-11

Plant-Precast Architectural Concrete

SECTION 07920  
JOINT SEALANTS

PART 1 - GENERAL

1.1. DESCRIPTION

- A. This Section describes the requirements for furnishing and installing joint sealants.

1.2. RELATED SECTIONS:

- A. None.

1.3. SUBMITTALS

- A. Product Data: Manufacturer's technical data for each product required, including instructions for joint preparation and sealant application. Include certification by joint sealant manufacturer that sealants, primers, and cleaners comply with local regulations controlling the use of volatile organic compounds (VOC).
- B. Samples: Manufacturer's bead samples of actual products showing full range of colors available, for each product exposed to view. Architect to select colors.
- C. Test Reports:
1. Certified test results of elastomeric sealants showing compliance with specified requirements. Include results of aged performances including hardness, stain-resistance, adhesion and cohesion under cyclic movement, low temperature flexibility, modulus of elasticity at 100-percent strain, affects of heat and aging, and affects of accelerated weathering.
  2. Preconstruction field test results indicating which products and joint preparation methods demonstrated acceptable adhesion to joint substrates.
- D. Certificates: Manufacturer's certification that joint sealants comply with specified requirements and are suitable for uses indicated.

1.4. QUALITY ASSURANCE

- A. Installer's Qualifications: Completion of at least 3 installations similar in type and size to this Project.

- B. Obtain joint sealant materials from a single manufacturer for each product required unless otherwise approved.
  - C. Preconstruction Compatibility and Adhesion Testing: Submit sample substrate materials to be sealed to joint sealant manufacturer for testing of adhesion and for compatibility with secondary seals.
    - 1. Determine if priming and/or other preparation techniques are required.
    - 2. Determine compatibility of exterior joint sealant with stone material to be used. Verify that joint sealant oils do not migrate onto stone face causing visual banding while wet or dry.
    - 3. Testing for adhesion is not required if sealant manufacturer has performed previous testing of proposed sealants for adhesion to and compatibility with required joints substrates.
  - D. Preconstruction Field Testing: Prior to installation of joint sealants, field-test adhesion to joint substrates.
    - 1. Install joint sealants in 5-foot joint lengths. Allow to cure before testing. Test adhesion by pulling sealant out of joint.
    - 2. Perform field tests for each type of elastomeric sealant and joint substrate.
    - 3. Arrange for tests to take place with joint sealant manufacturer's technical representative present.
    - 4. Report whether or not sealant in joint connected to pulled-out portion failed to adhere to joint substrates or tore cohesively. Include data on pull distance used to test each type of product and joint substrate.
    - 5. Sealants not evidencing adhesive failure from testing, in absence of other indications of noncompliance with requirements, will be considered satisfactory. Do not use sealants that fail to adhere to joint substrate during testing.
- 1.5. PRODUCT DELIVERY, STORAGE, AND HANDLING
- A. Deliver materials in the unopened, original containers or unopened packages with manufacturer's name, labels, product identification, color, expiration period, curing time and mixing instructions for multi-component materials.
  - B. Store materials in the original, unopened containers or packages, and under conditions recommended by manufacturers.
- 1.6. PROJECT CONDITIONS

- A. Environmental Conditions: Do not install sealants when ambient and substrate temperature conditions are outside limits permitted by joint sealant manufacturer, or to wet joint substrates.
- B. Joint Width Conditions: Do not install sealants when joint widths are less than permitted by sealant manufacturer.
- C. Joint Substrate Conditions: Do not proceed with installation of joint sealants until contaminants capable of interfering with their adhesion are removed from joint substrates.

1.7. WARRANTY

- A. Exterior Sealants: Furnish a written warranty against leaks or other defects of materials and workmanship for a period of 10-years. Defects include but are not limited to changes in the structural, physical or chemical properties of the sealant materials that impair function or require abnormal maintenance, changes in surface finish, color or texture, failure in adhesion, weather resistance or durability, failure to prevent entry of water, or failure to comply with specified requirements.
- B. This warranty shall not cover formation of cracks or defects in substrate materials adjacent to the seal, joint movement in excess of movement rating of sealant, or physical damage caused by others.
- C. Repair or replace defective materials and workmanship during warranty period without expense to Owner, including removal and replacement of other items as required.
- D. This warranty shall be in addition to and not a limitation of other rights the Owner may have against the Contractor under the Contract Documents.

PART 2 - PRODUCTS

2.1. MATERIALS, GENERAL

- A. Provide color of exposed joint sealants as selected. Custom colors will be used.
- B. Provide joint sealers, joint fillers and other materials that are compatible with one another and with joint substrates, as demonstrated by testing and field experience.

2.2. ELASTOMERIC JOINT SEALANTS

- A. Exterior Building Sealant: Either one-part silicone complying with ASTM C920, Type S, Grade NS, Class 25, Use NT, M, G, A, and O or multi-component polyurethane complying with ASTM C920, Type M, Grade NS, Class 25, Use NT, M, A, and O. Dow Corning Corp. "790", Tremco "Spectrem 1" or approved equal. Sealant shall resist ultra-violet, heat, ozone and moisture exposure and shall withstand substrate surface temperatures as high as 250-deg. F.
- B. Sanitary Sealant: One-part mildew-resistant silicone; ASTM C920 Type S; Grade NS; Class 25; Uses NT, G, A and O; formulated with fungicide for sealing interior joints with nonporous substrates around ceramic tile, showers, sinks and plumbing fixtures; Dow Corning Corp. "786 Mildew Resistant", General Electric Co. "Sanitary 1700", Sonneborn Building Product Div. "Sonolastic Omnipus", Tremco Tremsil 200 or approved equal.
- C. Horizontal Joint Sealant: Two-part pourable urethane; ASTM C920, Type M; Grade P; Class 25; Uses T, M, A and O; Pecora Corp. "NR-200 Urexpam", Sonneborn "Sonolastic Paving Joint Sealant", Tremco, Inc. "THC-900/901" or approved equal. Horizontal joint sealant shall have a minimum Shore A hardness of 30.

2.3. LATEX JOINT SEALANTS

- A. Interior Building Sealant: Acrylic-emulsion; one-part, nonsag, mildew-resistant, complying with ASTM C834, formulated to be paintable; Pecora Corp. "AC-20", Sonneborn "Sonolac", Tremco Inc. "Tremco Acrylic Latex 834" or approved equal.

2.4. JOINT FILLERS FOR CONCRETE PAVING

- A. Joint Filler: Preformed cork strips complying with ASTM D1752 for Type II or preformed sponge rubber strips complying with ASTM D1752 for Type I.

2.5. JOINT SEALANT BACKING

- A. Provide sealant backings which are non-staining; are compatible with joint substrates, sealants, primers and other joint fillers; and are approved by sealant manufacturer.

- B. Plastic Foam Joint-Fillers: Preformed, compressible, resilient, non-waxing, non- extruding strips of plastic foam, of size, shape and density to control sealant depth.
- C. Bond-Breaker Tape: Polyethylene tape or other plastic tape as recommended by sealant manufacturer. Provide self-adhesive tape where applicable.

## 2.6. MISCELLANEOUS MATERIALS

- A. Primer: As recommended by joint sealant manufacturer for adhesion of sealant to joint substrates.
- B. Cleaners for Nonporous Surfaces: Non-staining, chemical cleaner of type acceptable to manufacturer of sealant and sealant backing materials which are not harmful to substrates and adjacent nonporous materials.
- C. Masking Tape: Non-staining, non-absorbent type compatible with joint sealants and to surfaces adjacent to joints.

## PART 3 - EXECUTION

### 3.1. PREPARATION

- A. Surface Cleaning of Joints: Clean out joints immediately before installing joint sealants.
  - 1. Remove foreign material from joint substrates which could interfere with adhesion of joint sealant, including dust, paints, oil, grease, waterproofing, water repellents, water, and surface dirt.
  - 2. Clean porous surfaces, by brushing, grinding, blast cleaning, mechanical abrading, or acid washing to produce a clean, sound substrate. Remove loose particles remaining from cleaning operations by vacuuming or blowing out joints.
  - 3. Remove laitance and form release agents from concrete.
  - 4. Clean non-porous surfaces by chemical cleaners or other means which are not harmful to substrates or leave residues capable of interfering with adhesion of joint sealants.
- B. Joint Priming: Prime joint substrates where recommended by joint sealant manufacturer. Apply primer to comply with joint sealant manufacturer's recommendations. Confine primers to areas of joint sealant bond, do not allow spillage or migration onto adjoining surfaces.



- C. Masking Tape: Use masking tape where required to prevent contact of sealant with adjoining surfaces. Remove tape immediately after tooling without disturbing joint seal.

### 3.2. INSTALLATION OF JOINT SEALANTS

- A. Comply with joint sealant manufacturers' printed installation instructions applicable to products and applications indicated, except where more stringent requirements apply. Provide temporary ventilation during installation of interior joint sealants.
- B. Sealant Installation Standard: Comply with recommendations of ASTM C1193 for use of joint sealants as applicable to materials, applications and conditions indicated.
- C. Installation of Sealant Backings: Install sealant backings to comply with the following requirements:
  - 1. Install joint-fillers to provide sealant support for optimum performance cross-sectional shapes and depths.
    - a. Do not leave gaps between ends of joint-fillers.
    - b. Do not stretch, twist, puncture or tear joint-fillers.
    - c. Remove absorbent joint-fillers which have become wet prior to sealant application and replace with dry material.
- D. Install bond breaker tape between sealants and joint-fillers, compression seals or back of joints where required to prevent third-side adhesion of sealant to back of joint.
- E. Installation of Sealants: Install sealants by proven techniques to contact and full wet joint substrates, completely filling recesses provided for each joint configuration and providing uniform, optimum performance cross-sectional shapes and depths.
- F. Tooling of Non-sag Sealants: Tool sealants to form smooth, uniform beads of configuration indicated, to eliminate air pockets and to ensure contact and adhesion of sealant with sides of joint. Remove excess sealants from surfaces adjacent to joint. Do not use tooling agents which discolor sealants or adjacent surfaces or are not approved by sealant manufacturer.

### 3.3. PROTECTION AND CLEANING

- A. Protect joint sealants during and after curing period from contact with contaminating substances or from damage.
- B. Cut out and remove damaged or deteriorated joint sealers and reseal joints with matching new materials.
- C. Clean off excess sealants or sealant smears adjacent to joints as work progresses by methods and with cleaning materials approved by sealant manufacturer.

END OF SECTION

