

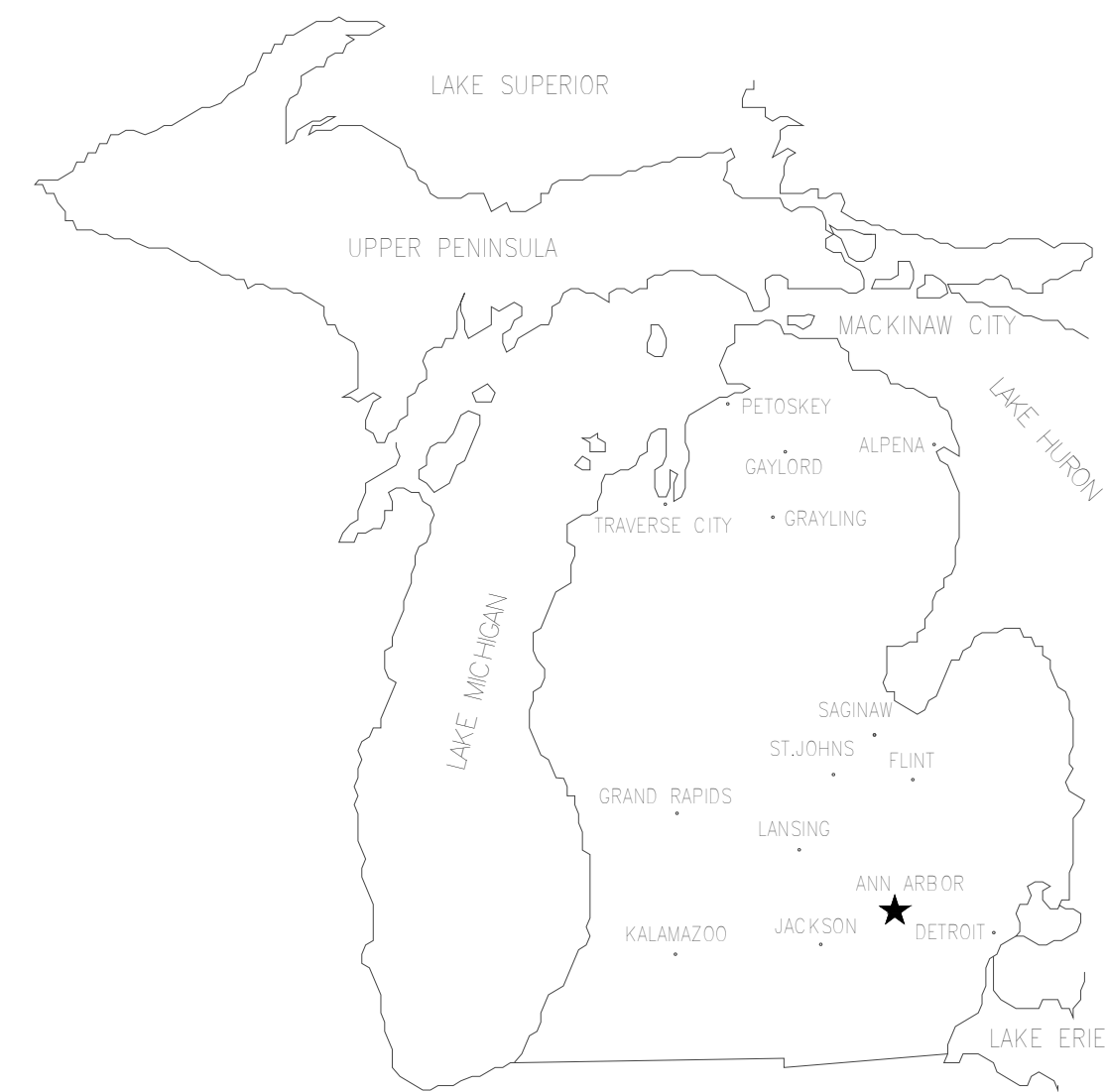

# RENOVATIONS FOR: ANN ARBOR VAMC UPGRADE MEDICAL GAS SYSTEM 2215 Fuller Road, Ann Arbor, MI 48105 506-14-103

ISSUE DATE: 11-17-2014  
100% BID DOCUMENTS



**LOCATION MAP**  
NO SCALE

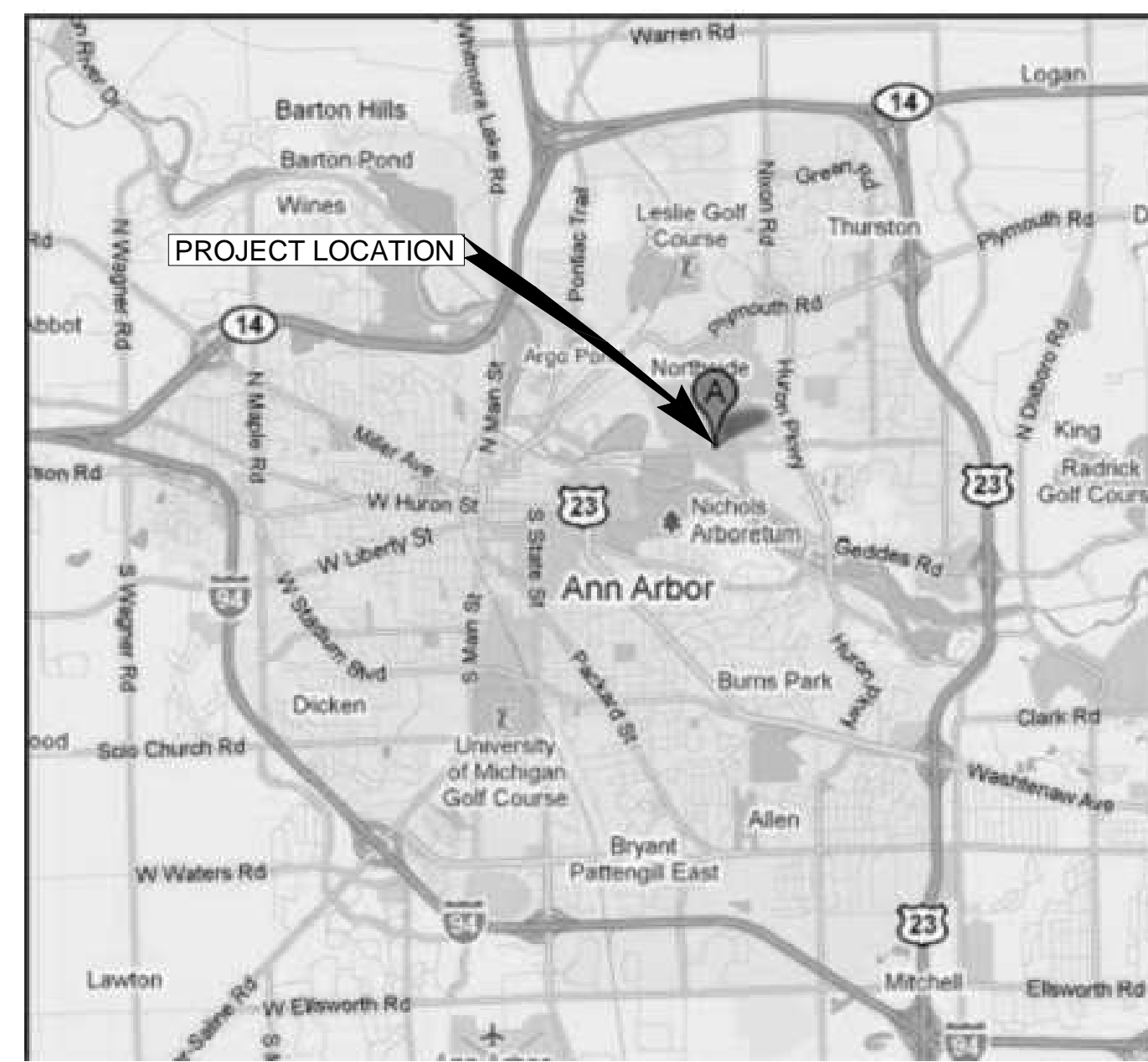

**VICINITY MAP**  
NO SCALE

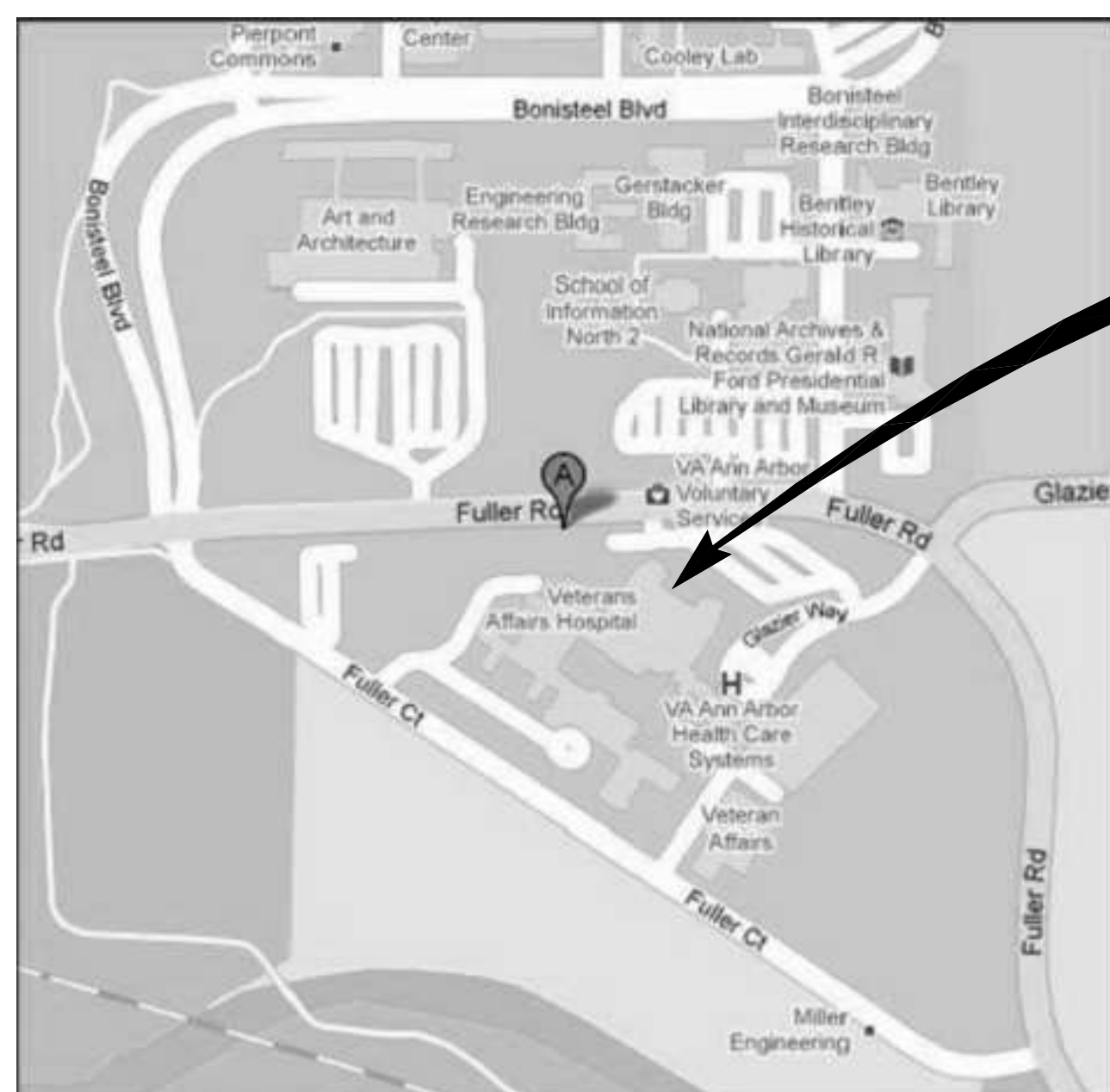

**AREA MAP**  
NO SCALE

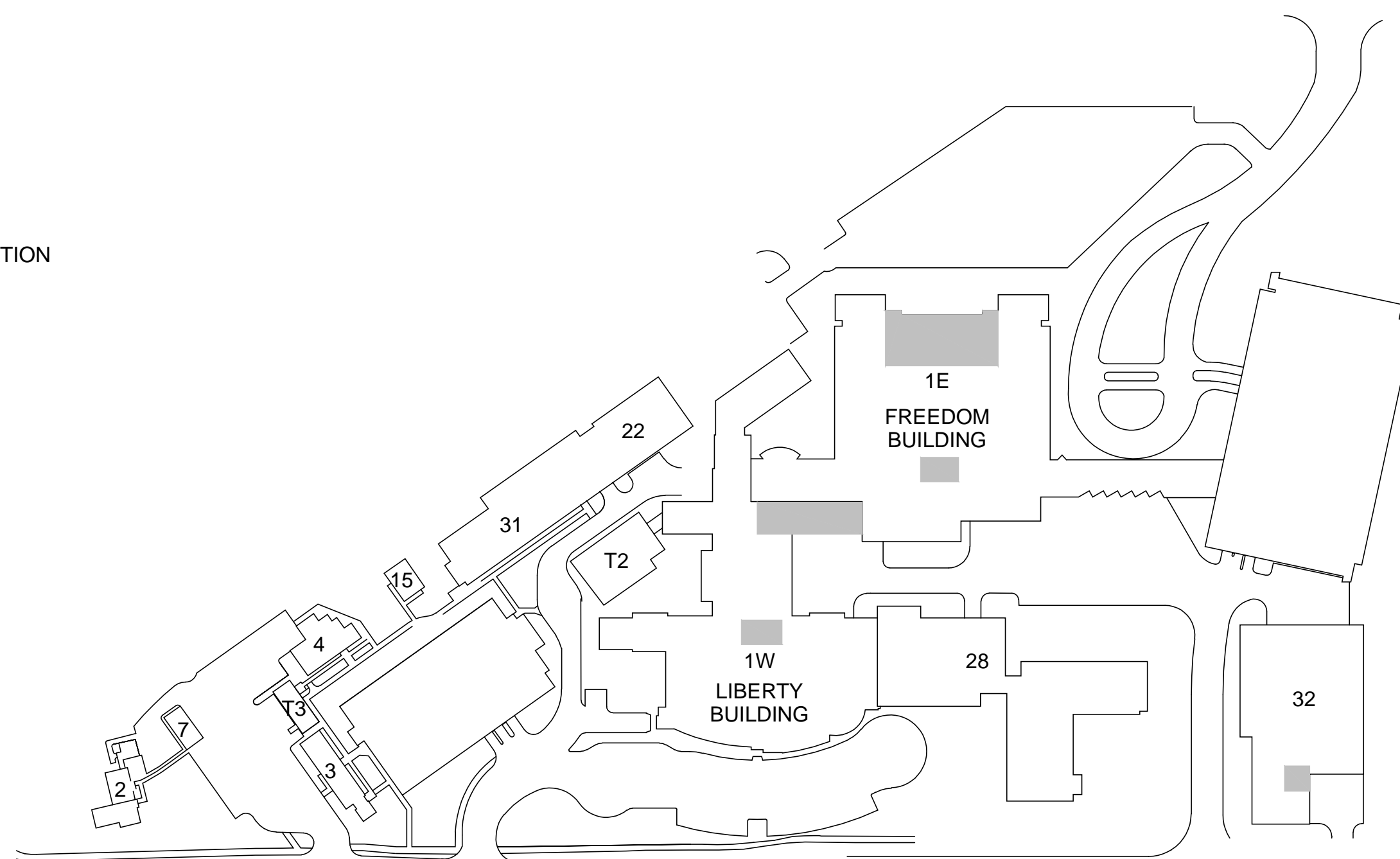

**KEY PLAN**  
NO SCALE

DRAWING INDEX	
SHEET #	SHEET NAME
G-001	COVER SHEET
P-110	FREEDOM BUILDING 1E MEDICAL GAS PLANS
P-111	LIBERTY BUILDING 1W MEDICAL GAS PLANS
P-140	LIBERTY BUILDING 1W MEDICAL GAS PLANS
P-500	MEDICAL GAS DETAILS
P-501	MEDICAL GAS DETAILS
P-502	MEDICAL GAS DETAILS
P-503	MEDICAL GAS DETAILS
P-504	MEDICAL GAS DETAILS
P-600	MEDICAL GAS SCHEDULES

<b>CONSULTANTS:</b> 725 Prudden Street Lansing, MI 48906 - 517.371.1200 123 West Main Street, Suite 200 Gaylord, MI 49735 - 689.732.8131 648 Monroe Avenue NW, Suite 210 Grand Rapids, MI 49503 - 616.454.9414 1211 Ludington Street Escanaba, MI 49829 - 906.233.9360	 elevating human achievement	<b>ARCHITECT/ENGINEERS:</b>  ENGINEERS - SURVEYORS - CONSULTANTS - LANDSCAPE ARCHITECTS - LAND PLANNERS 638 SOUTH GRAND AVE. FOWLERVILLE, MICHIGAN 48836 (OFFICE) 517-223-3512 (FAX) 517-223-9987	<b>REVISIONS:</b> <table border="1"> <tr><td> </td><td> </td><td> </td></tr> <tr><td> </td><td> </td><td> </td></tr> <tr><td> </td><td> </td><td> </td></tr> <tr><td> </td><td> </td><td> </td></tr> <tr><td> </td><td> </td><td> </td></tr> <tr><td> </td><td> </td><td> </td></tr> </table>																			<b>DRAWING TITLE:</b> COVER SHEET <b>ISSUED DATE:</b> 11-17-2014 <b>BUILDING NUMBER:</b> BUILDING 1 <b>PROJECT:</b> UPGRADE MEDICAL GAS SYSTEM	<b>VA PROJECT NAME:</b> UPGRADE MEDICAL GAS SYSTEM <b>VA PROJECT NUMBER:</b> 506-14-103 <b>C2AE PROJECT NUMBER:</b> 14-0017 <b>DRAWING NUMBER:</b> G-001	<b>DEPARTMENT OF VETERANS AFFAIRS</b>

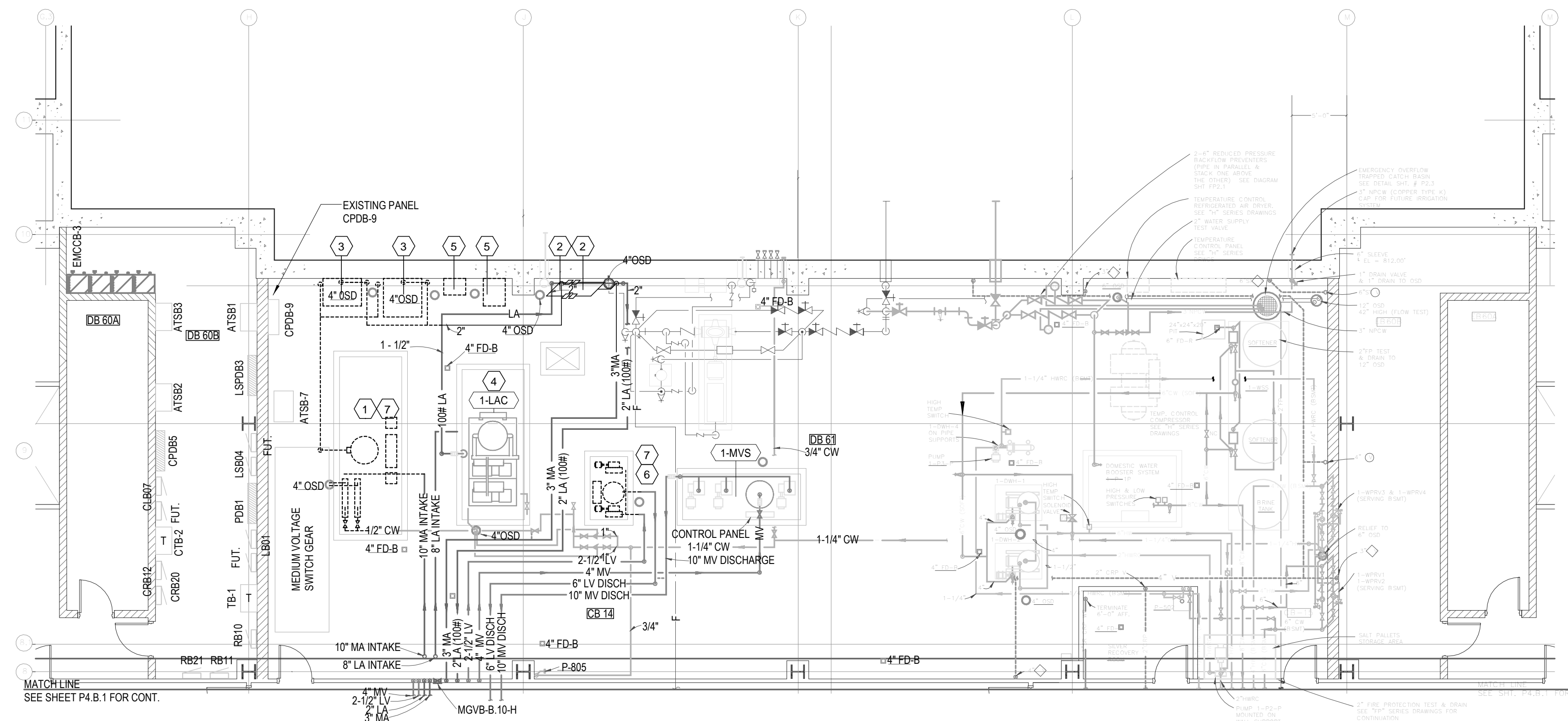

FREEDOM BUILDING 1E - BASEMENT MEDICAL GAS DEMOLITION PLAN  
1/8" = 1'-0"

**MEDICAL GAS DEMOLITION NOTES:**

- 1 REMOVE AND REPLACE THE EXISTING MEDICAL AIR SOURCE COMPRESSOR EQUIPMENT, INCLUDING THE ASSOCIATED DRYERS, DRYER FILTERS, AND SOURCE ALARM DEVICES.
- 2 REMOVE EXISTING CARBON MONOXIDE AND DEWPOINT SENSORS FOR BOTH THE MEDICAL AIR AND LAB AIR SYSTEM. REPAIR/REWORK SUPPLY PIPING AS NEEDED.
- 3 REMOVE EXISTING MEDICAL AIR DESSICANT AND --- DRYERS.
- 4 EXISTING LABORATORY AIR SOURCE COMPRESSOR PACKAGE IS TO REMAIN. CARBON MONOXIDE SENSOR, DEW POINT SENSOR, AND MAIN LINE PRESSURE SENSOR ARE TO BE REPLACED.
- 5 REMOVE LABORATORY AIR DESSICANT AND REFRIGERANT DRYERS WHICH WERE PREVIOUSLY ABANDONED IN PLACE.
- 6 REMOVE THE EXISTING LABORATORY VACUUM SOURCE EQUIPMENT, INCLUDING THE ASSOCIATED FILTERS AND SOURCE ALARM DEVICES.
- 7 DEMOLISH EXISTING ELECTRICAL CONDUIT AND CONDUCTORS BACK TO PANEL CPDB-9. REMOVE EXISTING CIRCUIT BREAKER AND TURN OVER TO OWNER.

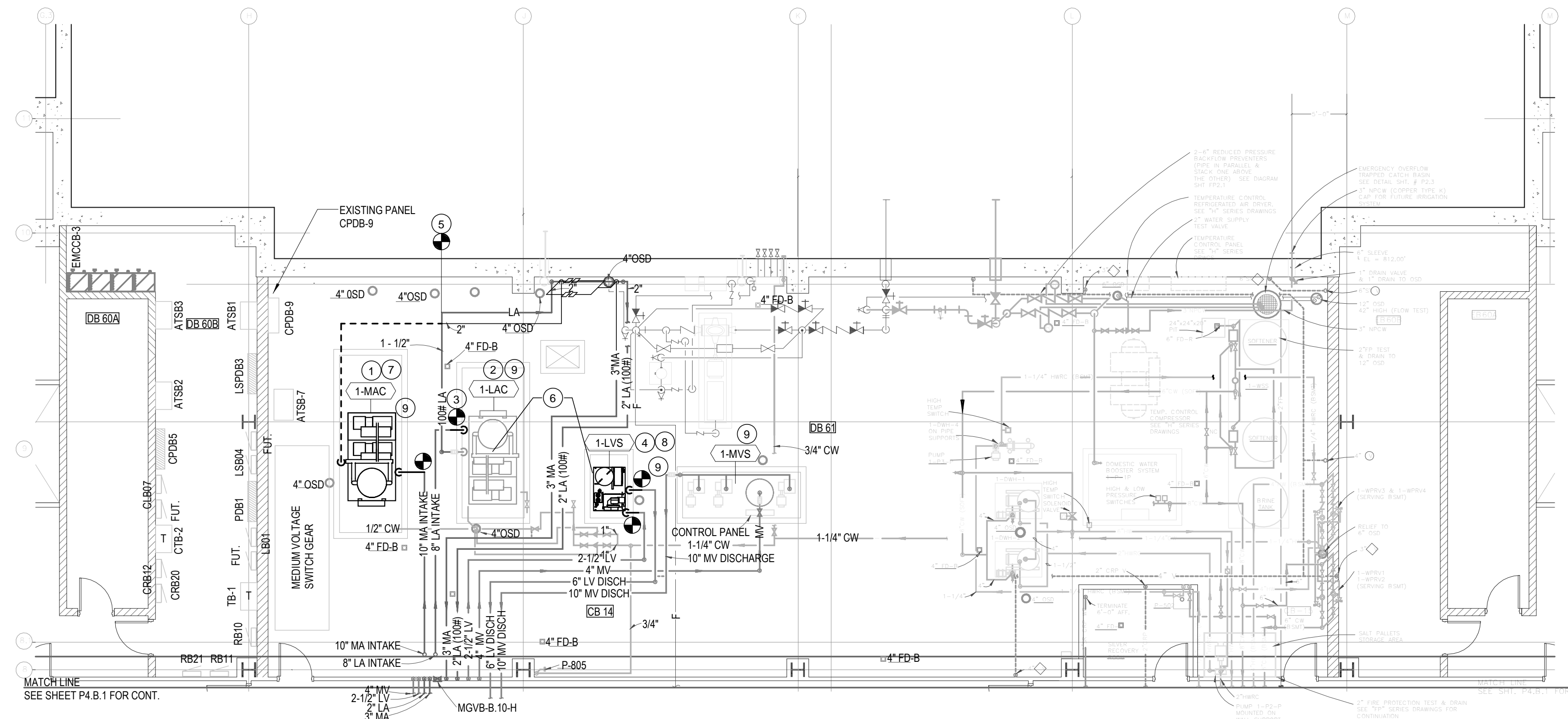

FREEDOM BUILDING 1E - BASEMENT MEDICAL GAS PLAN  
1/8" = 1'-0"

**MEDICAL GAS PLAN NOTES:**

- 1 INSTALL NEW PACKAGED AND FACTORY ASSEMBLED MEDICAL AIR SYSTEM WITH MULTI-PLEX COMPRESSORS, AIR-COOLED AFTER COOLERS, ASME RECEIVER TANK, DUPLEX DESSICANT AIR DRYERS, PRE AND AFTER FILTERS, AND NFPA COMPLIANT CONTROL PANEL WITH OPERATING DISPLAYS AND LOCAL ALARMS. INCLUDE ALL SOURCE ALARM DEVICES. INTEGRATE ALARMS AND SENSORS INTO NEW MASTER ALARM SYSTEM.
- 2 INSTALL NEW CARBON MONOXIDE SENSOR, DEW POINT SENSOR, FOR EXISTING LABORATORY AIR SYSTEM. INTEGRATE ALARMS AND SENSORS INTO NEW MASTER ALARM SYSTEM.
- 3 CONNECT EXISTING FRESH AIR INTAKE TO EXISTING LABORATORY AIR COMPRESSORS. PROVIDE AND INSTALL NEW INTAKE MANIFOLD FOR MULTI-COMPRESSOR PACKAGE.
- 4 INSTALL NEW PACKAGED LABORATORY VACUUM PUMP SYSTEM WITH ASME RECEIVER TANK AND NFPA COMPLIANT CONTROL PANEL WITH OPERATING DISPLAYS AND LOCAL ALARMS. INCLUDE ALL SOURCE ALARM DEVICES. INTEGRATE ALARMS AND SENSORS INTO NEW MASTER ALARM SYSTEM.
- 5 PROVIDE CONNECTION TO EXISTING MEDICAL AIR SUPPLY MAIN FOR USE OF TEMPORARY MEDICAL AIR SOURCE PRIOR TO SHUT-DOWN OF EXISTING SOURCE EQUIPMENT. PROVIDE TEMPORARY SOURCE OF MEDICAL AIR AS NEEDED TO SATISFY THE EXISTING LINE DISTRIBUTION. COORDINATE CHANGE-OVERS WITH COR. TEMPORARY DISRUPTION OF MEDICAL SOURCE AIR SHALL NOT EXCEED 30 MINUTES UNLESS APPROVED BY THE COR.
- 6 TEMPORARY DISRUPTION OF LABORATORY SOURCE AIR OR VACUUM SHALL NOT EXCEED 3 HOURS UNLESS APPROVED BY THE COR.
- 7 PROVIDE (3) #10 CU (1) #8 CU GND, 1-1/2" FROM CPDB-9 TO 1-MAC. PROVIDE NEW 150A/3P, 65KAIC, ELECTRONIC TRIP BREAKER IN EXISTING SQUARE D LINE PANELBOARD.
- 8 PROVIDE (3) #10CU (1) #10 CU GND, 3/4" FROM CPDB-9 TO 1-LVS. PROVIDE NEW 25A/3P, 65KAIC BREAKER IN EXISTING SQUARE D LINE PANELBOARD.
- 9 RELABEL ALL MEDICAL GAS PIPING AND MASTER ALARM DEVICES AND WIRING PER NFPA 99.

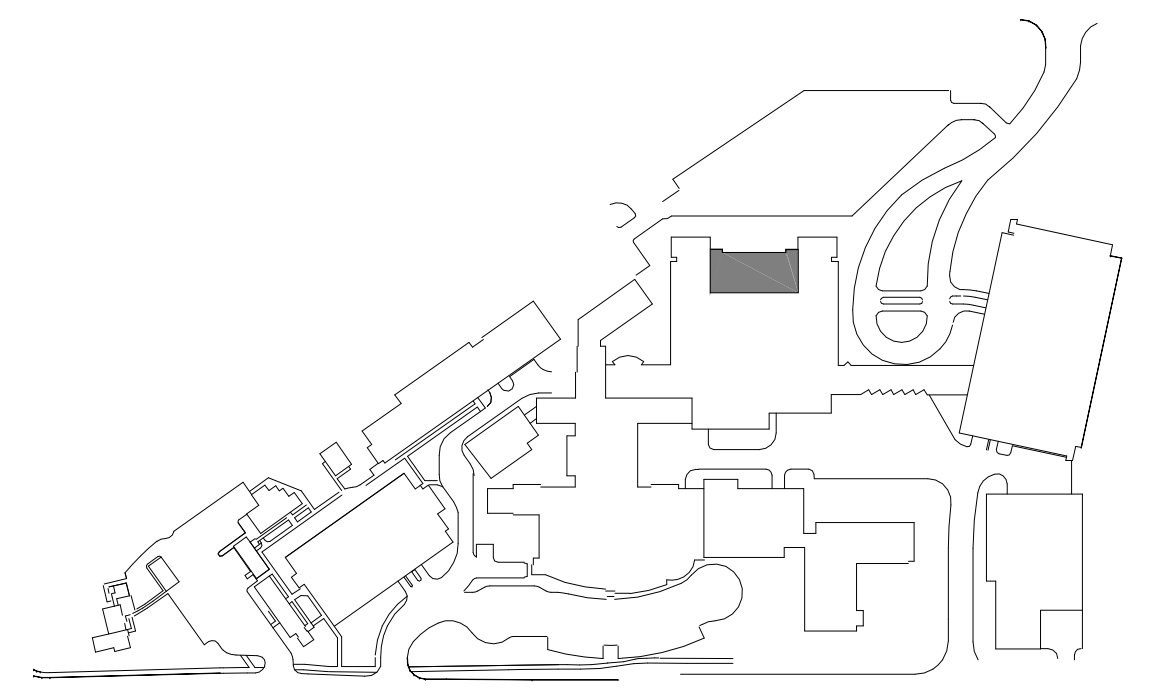

<b>CONSULTANTS:</b> 725 Prudden Street Lansing, MI 48906 - 517.371.1200 123 West Main Street, Suite 200 Gaylord, MI 49735 - 589.732.8131 648 Monroe Avenue NW, Suite 210 Grand Rapids, MI 49503 - 616.454.9414 1211 Ludington Street Escanaba, MI 49829 - 906.233.9360		<b>ARCHITECT/ENGINEERS:</b> ENGINEERS - SURVEYORS - CONSULTANTS - LANDSCAPE ARCHITECTS - LAND PLANNERS <b>MEGA</b> Moment Engineering Group Associates, Inc. 638 SOUTH GRAND AVE. FOWLERVILLE, MICHIGAN 48836 (OFFICE) 517-223-3512 (FAX) 517-223-9987		<b>REVISIONS:</b> <table border="1"> <tr><td> </td><td> </td><td> </td></tr> <tr><td> </td><td> </td><td> </td></tr> <tr><td> </td><td> </td><td> </td></tr> <tr><td> </td><td> </td><td> </td></tr> <tr><td> </td><td> </td><td> </td></tr> </table>																<b>DRAWING TITLE:</b> <b>FREEDOM BUILDING 1E          MEDICAL GAS PLANS</b> DATE: 11-17-2014 BUILDING NUMBER: 1E PLOT SCALE: As Indicated PROJECT: UPGRADE MEDICAL GAS SYSTEM	VA PROJECT NAME: UPGRADE MEDICAL GAS SYSTEM VA PROJECT NUMBER: 506-14-103 C2AE PROJECT NUMBER: 14-0017 DRAWING NUMBER: <b>P-110</b>	<b>DEPARTMENT OF          VETERANS AFFAIRS</b>

100% BID DOCUMENTS

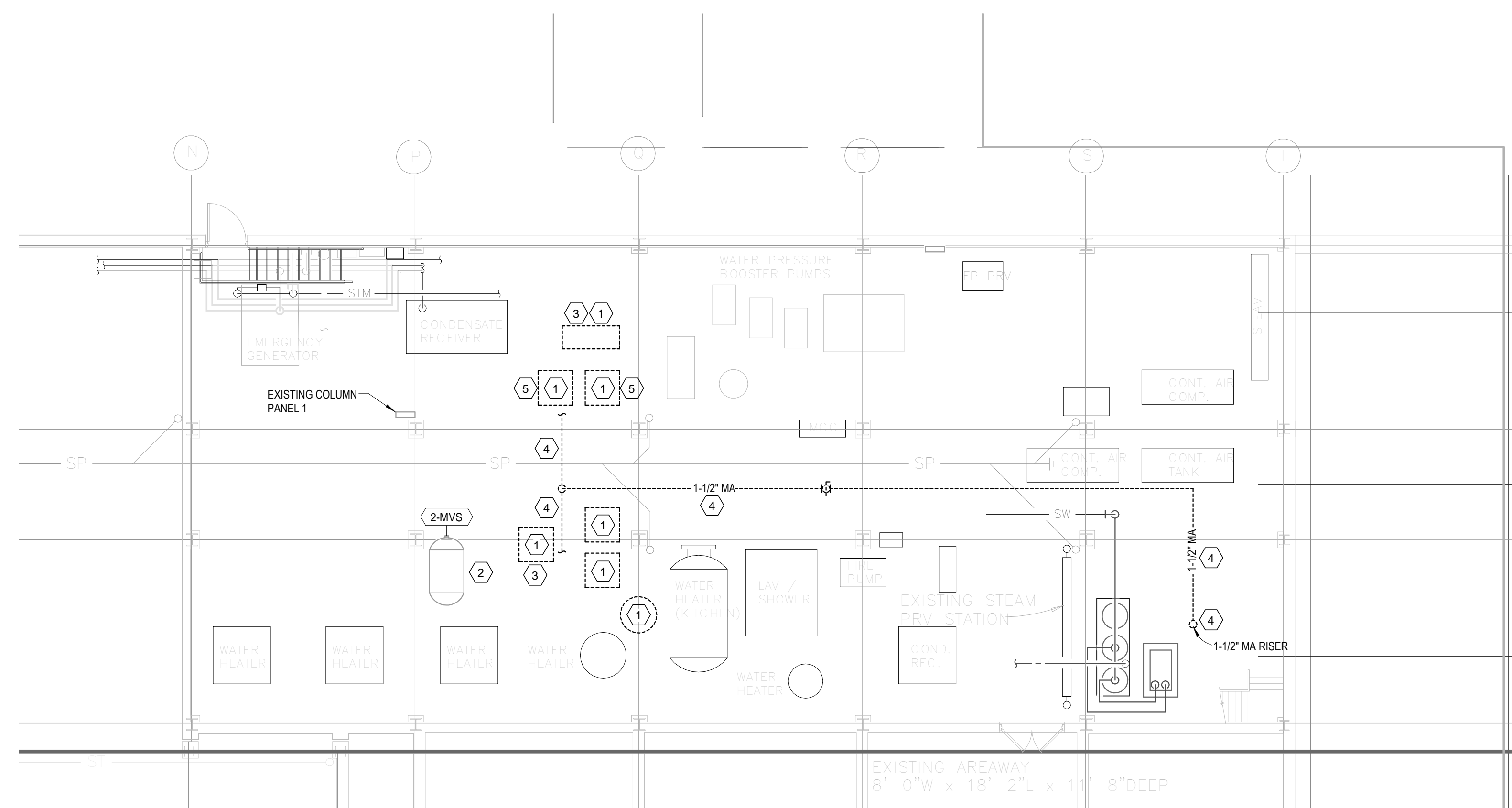

**MEDICAL GAS DEMOLITION NOTES:**

- ① REMOVE THE EXISTING MEDICAL AIR SOURCE EQUIPMENT, INCLUDING ASSOCIATED DRYERS, FILTERS, AND SOURCE ALARM DEVICES.
- ② EXISTING MEDICAL VACUUM SOURCE EQUIPMENT IS TO REMAIN.
- ③ REMOVE EXISTING DOMESTIC WATER LINES TO AFTER COOLERS, CAP AT MAIN.
- ④ DEMOLISH EXISTING 1-1/2" MA MAIN IN BASEMENT AND RISER UP TO FOURTH FLOOR AND ALL HANGERS AND SUPPORTS. REFER TO SHEET P-140 FOR CONTINUATION.
- ⑤ DEMOLISH EXISTING FEED FOR MEDICAL AIR COMPRESSORS, INCLUDING CONDUIT, CONDUCTORS BACK TO COLUMN PANEL 1. REMOVE ASSOCIATED CIRCUIT BREAKERS AND TURN OVER TO OWNER.

LIBERTY BUILDING 1W - BASEMENT MEDICAL GAS DEMOLITION PLAN  
1/8" = 1'-0"

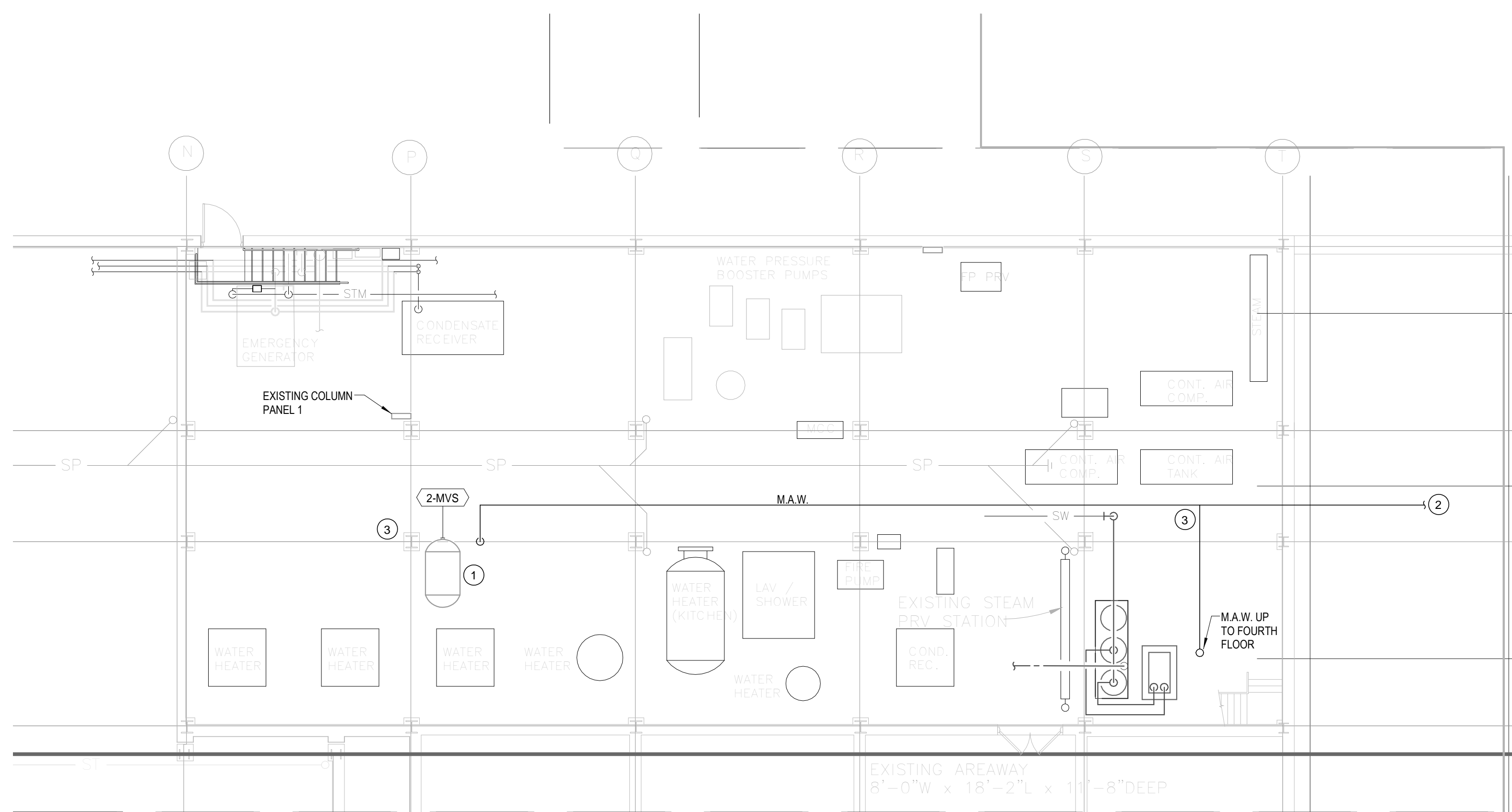

**MEDICAL GAS PLAN NOTES:**

- ① INTEGRATE SOURCE ALARMS AND SENSORS INTO NEW MASTER ALARM SYSTEM.
- ② INSTALL NEW MASTER ALARM WIRING AND CONDUIT FROM NEW MASTER ALARM JUNCTION BOX TO SOURCE ALARM DEVICES ON 4TH FLOOR AND SUB-BASEMENT.
- ③ RELABEL ALL MEDICAL GAS PIPING AND MASTER ALARM DEVICES AND WIRING PER NFPA 99.

LIBERTY BUILDING 1W - BASEMENT MEDICAL GAS PLAN  
1/8" = 1'-0"

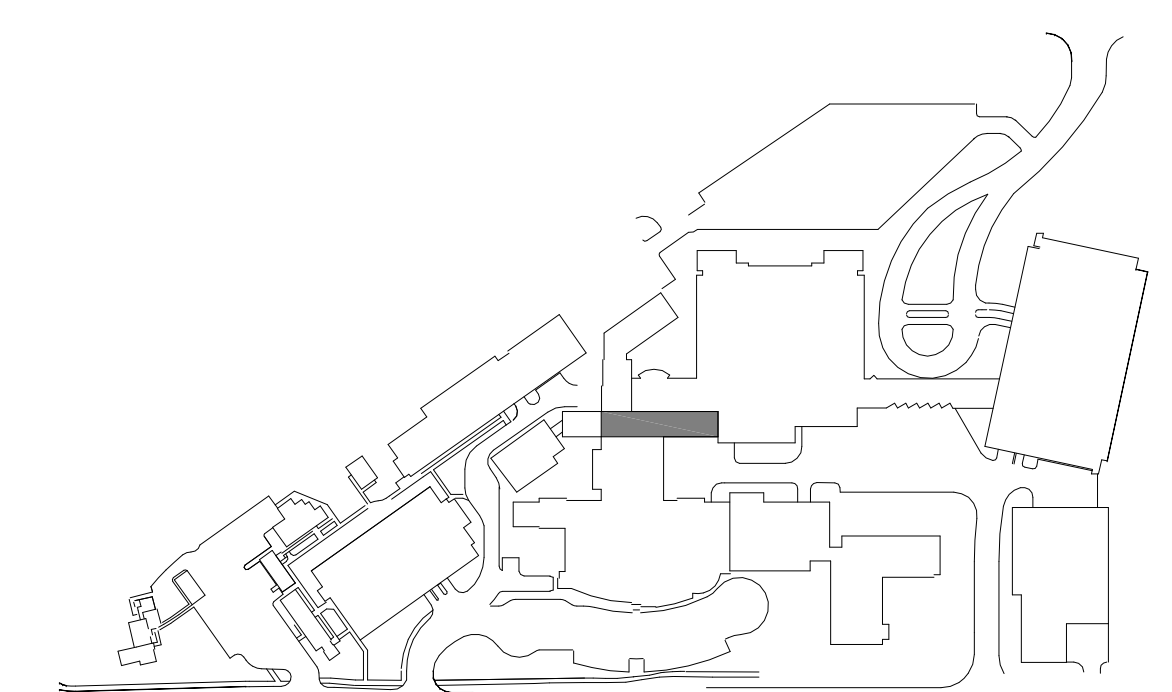

KEYPLAN

<b>CONSULTANTS:</b> 725 Prudden Street Lansing, MI 48906 - 517.371.1200 123 West Main Street, Suite 200 Gaylord, MI 49735 - 989.732.8131 648 Monroe Avenue NW, Suite 210 Grand Rapids, MI 49503 - 616.454.9414 1211 Ludington Street Escanaba, MI 49829 - 906.233.9360	 elevating human achievement	<b>ARCHITECT/ENGINEERS:</b>  Morning Engineering Group Associates, Inc. ENGINEERS - SURVEYORS - CONSULTANTS - LANDSCAPE ARCHITECTS - LAND PLANNERS 638 SOUTH GRAND AVE. FOWLERVILLE, MICHIGAN 48836 (OFFICE) 517-223-3512 (FAX) 517-223-9987	REVISIONS: _____ _____ _____ _____ _____	DRAWING TITLE: <b>LIBERTY BUILDING 1W          MEDICAL GAS PLANS</b>	VA PROJECT NAME: UPGRADE MEDICAL GAS SYSTEM VA PROJECT NUMBER: 506-14-103
			DATE: 11-17-2014	BUILDING NUMBER: 1W	PLOT SCALE: As Indicated
PROJECT: UPGRADE MEDICAL GAS SYSTEM					

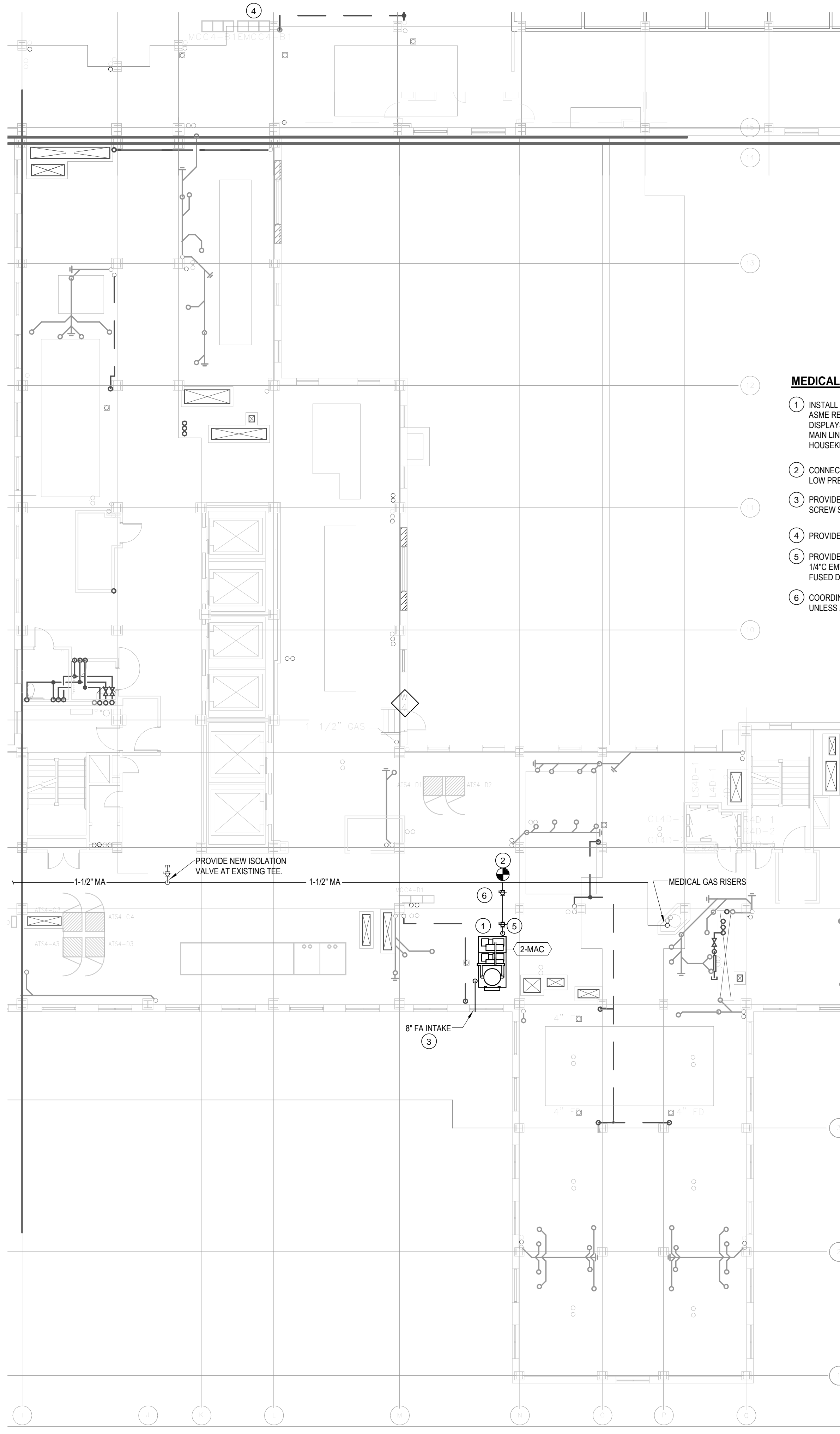

**MEDICAL GAS PLAN NOTES:**

- 1 INSTALL NEW PACKAGED AND FACTORY ASSEMBLED MEDICAL AIR SYSTEM WITH MULTI-PLEX COMPRESSORS, AIR-COOLED AFTER COOLERS, ASME RECEIVER TANK, DUPLEX DESICCANT AIR DRYERS, PRE AND AFTER FILTERS, AND NFPA COMPLIANT CONTROL PANEL WITH OPERATING DISPLAYS AND LOCAL ALARMS. INCLUDE ALL SOURCE ALARM DEVICES INCLUDING CARBON MONOXIDE SENSOR, DEW POINT SENSOR, AND MAIN LINE PRESSURE SENSOR. INTEGRATE ALARMS AND SENSORS INTO NEW MASTER ALARM SYSTEM. INSTALL ON NEW 4\"/>
- 2 CONNECT NEW 1-1/2\"/>
- 3 PROVIDE NEW 8\"/>
- 4 PROVIDE NEW 60A3P CIRCUIT BREAKER IN MOTOR CONTROL CENTER EMCC4-C1.
- 5 PROVIDE NEW 60A3P FUSED DISCONNECT AT 2-MAC. FUSE PER MANUFACTURER'S RECOMMENDATION. PROVIDE (3) ROLL (1) #10CU GND, 1-1/4\"/>
- 6 COORDINATE MEDICAL AIR SYSTEM CHANGE OVER WITH COR. TEMPORARY DISRUPTION OF MEDICAL AIR SHALL NOT EXCEED 30 MINUTES UNLESS APPROVED BY COR.

1 LIBERTY BUILDING 1W - FOURTH FLOOR MEDICAL GAS PLAN  
3/32" = 1'-0"

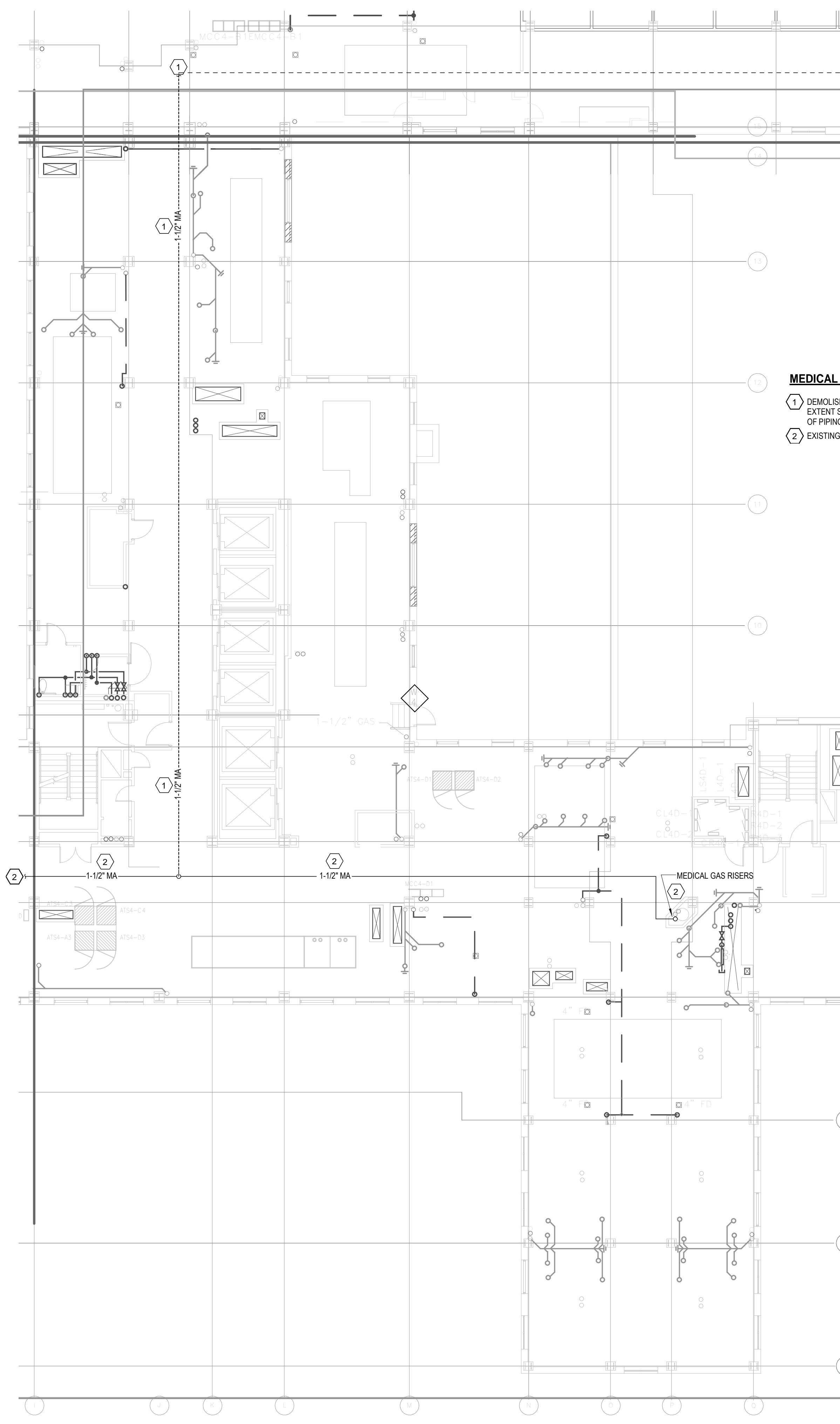

**MEDICAL GAS DEMOLITION NOTES:**

- 1 DEMOLISH EXISTING 1-1/2\"/>
- 2 EXISTING 1-1/2\"/>

2 LIBERTY BUILDING 1W - FOURTH FLOOR MEDICAL GAS DEMOLITION PLAN  
3/32" = 1'-0"

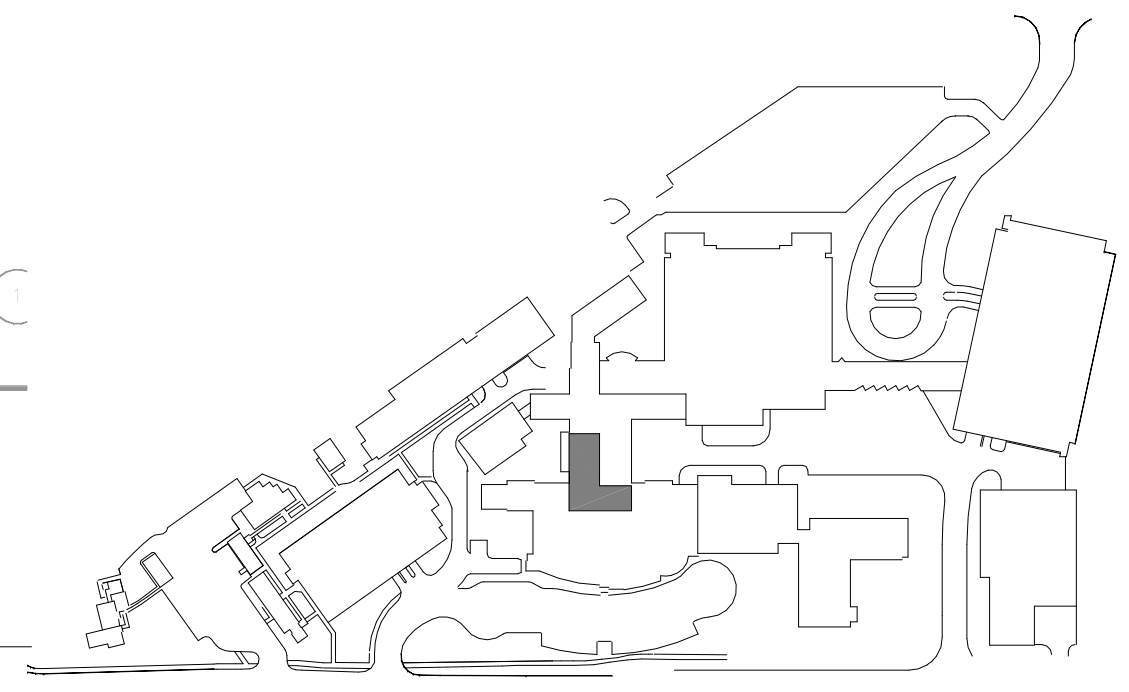

KEYPLAN

<b>CONSULTANTS:</b> 725 Prudden Street Lansing, MI 48906 - 517.371.1200 123 West Main Street, Suite 200 Gaylord, MI 49735 - 989.732.8131 648 Monroe Avenue NW, Suite 210 Grand Rapids, MI 49503 - 616.454.9414 1211 Ludington Street Escanaba, MI 49829 - 906.233.9360 	<b>ARCHITECT/ENGINEERS:</b>  <b>ENGINEERS - SURVEYORS - CONSULTANTS -          LANDSCAPE ARCHITECTS - LAND PLANNERS</b> 638 SOUTH GRAND AVE. FOWLERVILLE, MICHIGAN 48836 (OFFICE) 517-223-3512 (FAX) 517-223-9987	<b>REVISIONS:</b> <table border="1"> <tr><td> </td><td> </td><td> </td></tr> <tr><td> </td><td> </td><td> </td></tr> <tr><td> </td><td> </td><td> </td></tr> <tr><td> </td><td> </td><td> </td></tr> <tr><td> </td><td> </td><td> </td></tr> <tr><td> </td><td> </td><td> </td></tr> <tr><td> </td><td> </td><td> </td></tr> <tr><td> </td><td> </td><td> </td></tr> <tr><td> </td><td> </td><td> </td></tr> <tr><td> </td><td> </td><td> </td></tr> </table>																															<b>VA PROJECT NAME:</b> UPGRADE MEDICAL GAS SYSTEM <b>VA PROJECT NUMBER:</b> 506-14-103 <b>C2AE PROJECT NUMBER:</b> 14-0017 <b>DRAWING NUMBER:</b> <b>P-140</b>	<b>LIBERTY BUILDING 1W          MEDICAL GAS PLANS</b> <b>DATE:</b> 11-17-2014 <b>BUILDING NUMBER:</b> <b>PLOT SCALE:</b> As Indicated <b>PROJECT:</b> UPGRADE MEDICAL GAS SYSTEM	<b>100% BID DOCUMENTS</b> <b>DEPARTMENT OF          VETERANS AFFAIRS</b>
<b>LIBERTY BUILDING 1W - FOURTH FLOOR MEDICAL GAS PLAN</b> 3/32" = 1'-0"																																			

### LEGEND

- |            |   |      |                                      |
|------------|---|------|--------------------------------------|
| (LPMAMA)   | LOW PRESSURE MEDICAL AIR MASTER ALARM   | MA   | MEDICAL AIR                          |
| (HPMAMA)   | HIGH PRESSURE MEDICAL AIR MASTER ALARM  | FCW  | FACTORY CONTROL WIRING               |
| (DOMMA)    | DESICCANT DRYER MALFUNCTION MASTER ALARM  | MAW  | MASTER ALARM WIRING DRAIN            |
| (CMA)      | COMPRESSOR MALFUNCTION MASTER ALARM   | DR   | DRAIN                                |
| (DPHMA)    | DEW POINT HIGH MASTER ALARM   | DPMT | DEW POINT MONITOR TUBING 1/4"        |
| (CHMA-S)   | CARBON MONOXIDE HIGH MASTER ALARM - SYSTEM  | COT  | CARBON MONOXIDE TUBING 1/4"          |
| (CHTLA)    | COMPRESSOR HIGH TEMPERATURE LOCAL ALARM   | Y    | 1/4" AUTOMATIC CONDENSATE DRAIN VENT |
| (DFHPDMA)  | DESICCANT INLET FILTER HIGH PRESSURE DIFFERENTIAL MASTER ALARM  | PS   | OPERATING PRESSURE SWITCH            |
| (DFHPDMA)  | DESICCANT POST FILTER HIGH PRESSURE DIFFERENTIAL MASTER ALARM   | ACD  | AUTOMATIC CONDENSATE DRAIN           |
| (ACHATMA)  | AFTER COOLER HIGH AIR TEMPERATURE MASTER ALARM  | PS   | PRESSURE DIFFERENTIAL SWITCH         |
| (MFPDMA)   | MAIN FILTER BANK HIGH PRESSURE DIFFERENTIAL MASTER ALARM  | 3P   | 3 PIECE BALL VALVE                   |
| (RASHPDMA) | REFRIGERATED AIR DRYER FILTER HIGH PRESSURE DIFFERENTIAL MASTER ALARM   | NC   | NORMALLY CLOSED                      |
| (FDTCLA)   | FAILURE OF DESICCANT TOWER CYCLING LOCAL ALARM WIRED FROM DESICCANT CONTROL PANEL TO COMPRESSOR CONTROL PANEL. PROVIDE LOCAL ALARM ON COMPRESSOR CONTROL PANEL. | NO   | NORMALLY OPENED                      |
| (DHDPLA)   | DESICCANT HIGH DEW POINT LOCAL ALARM WIRED FROM DESICCANT CONTROL PANEL TO COMPRESSOR CONTROL PANEL. PROVIDE LOCAL ALARM ON COMPRESSOR CONTROL PANEL.           |      |                                      |

COMPRESSOR OPERATING SWITCH SETTING SCHEDULE				
PSI ON - PSI OFF	PRESS. SW #1	PRESS. SW #2	PRESS. SW #3	PRESS. SW #4
1-LAC	95-105	90-100	85-95	NONE
1-MAC QUADRIPLEX	95-105	90-100	85-95	80-90

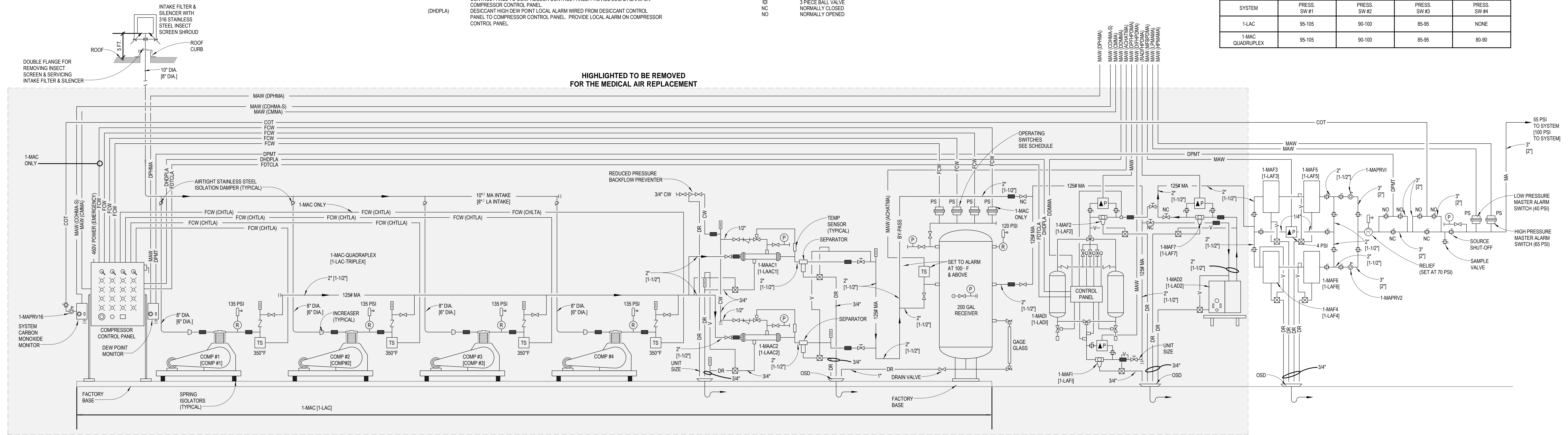

1 EXISTING MEDICAL AIR SYSTEM PIPING DIAGRAM (MEDICAL AIR BUILDING 1E SHOWN)  
N.T.S.

**NOTE:**

THE ABOVE DIAGRAM IS TAKEN FROM THE 1994 AS-BUILT DRAWINGS AND IS PROVIDED HERE FOR REFERENCE. THE INTENT OF THE DEMOLITION WORK FOR THE MEDICAL AIR SOURCE EQUIPMENT IS SHADDED.

INFORMATION SHOWN IN BRACKETS APPLIES TO THE ORIGINAL LABORATORY AIR SOURCE EQUIPMENT WHICH WAS REPLACED IN 2014 AND CAN BE IGNORED.

CONSULTANTS:  
725 Prudden Street  
Lansing, MI 48906 - 517.371.1200  
123 West Main Street, Suite 200  
Gaylord, MI 49735 - 689.732.8131  
648 Monroe Avenue NW, Suite 210  
Grand Rapids, MI 49503 -  
616.454.9414  
1211 Ludington Street  
Eastland, MI 49829 - 906.233.9380



ARCHITECT/ENGINEERS:  
Mountaintop Engineering Group Associates, Inc.  
ENGINEERS - SURVEYORS - CONSULTANTS -  
LANDSCAPE ARCHITECTS - LAND PLANNERS  
638 SOUTH GRAND AVE.  
FOWLERVILLE,  
MICHIGAN 48836  
(OFFICE) 517-223-3512  
(FAX) 517-223-9987

REVISIONS

DRAWING TITLE: <b>MEDICAL GAS DETAILS</b>			VA PROJECT NAME: UPGRADE MEDICAL GAS SYSTEM
DATE: 11-17-2014	BUILDING NUMBER:	PLOT SCALE: 1/8" = 1'-0"	VA PROJECT NUMBER: 508-14-103
PROJECT: UPGRADE MEDICAL GAS SYSTEM			C2AE PROJECT NUMBER: 14-0017
			DRAWING NUMBER: <b>P-500</b>

DEPARTMENT OF  
VETERANS AFFAIRS

100% BID DOCUMENTS

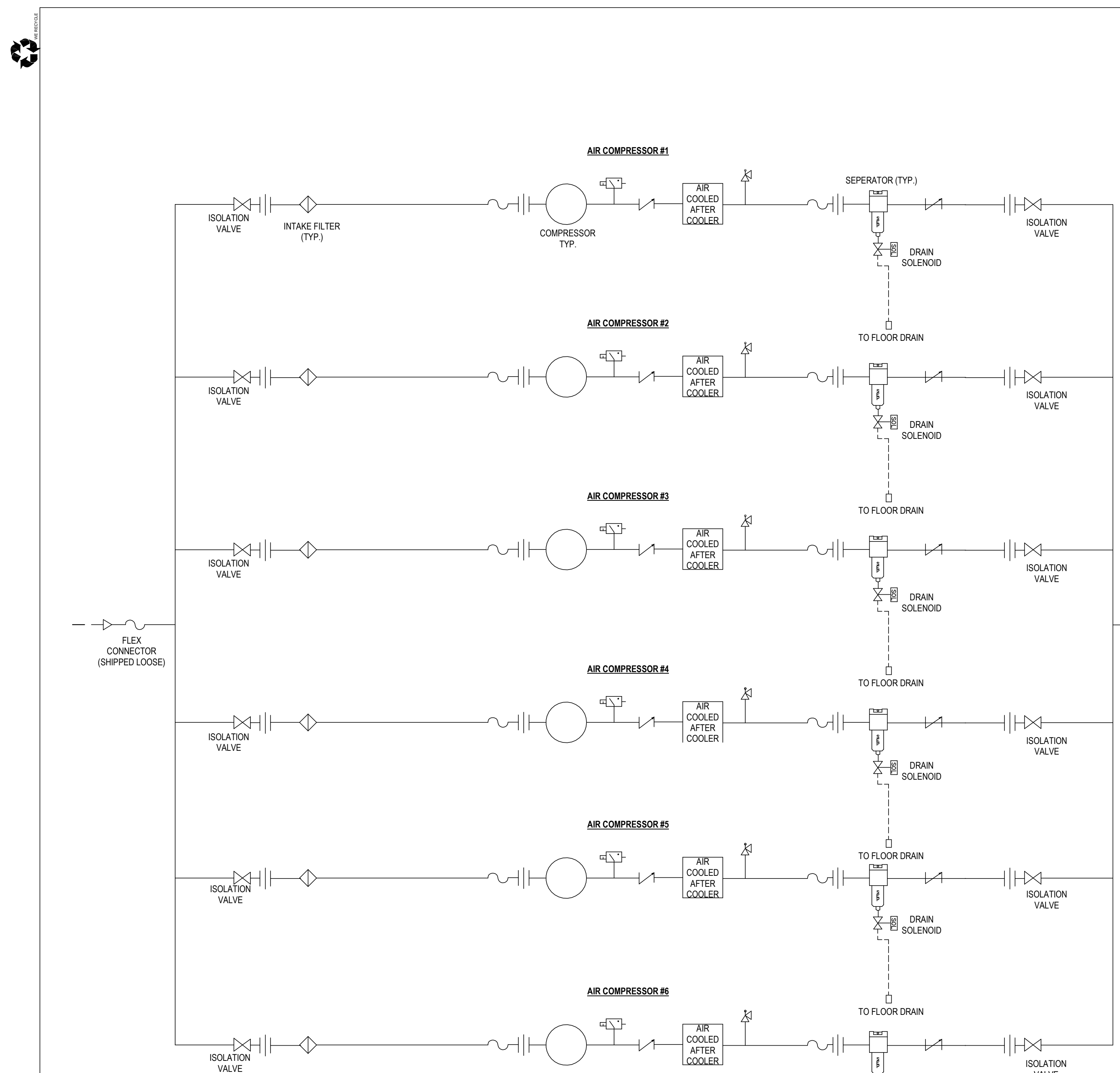

**1** P&ID HEXAPLEX SCROLL AIR SYSTEM WITH DESICCANT AIR DRYERS (1-MAC)  
N.T.S.

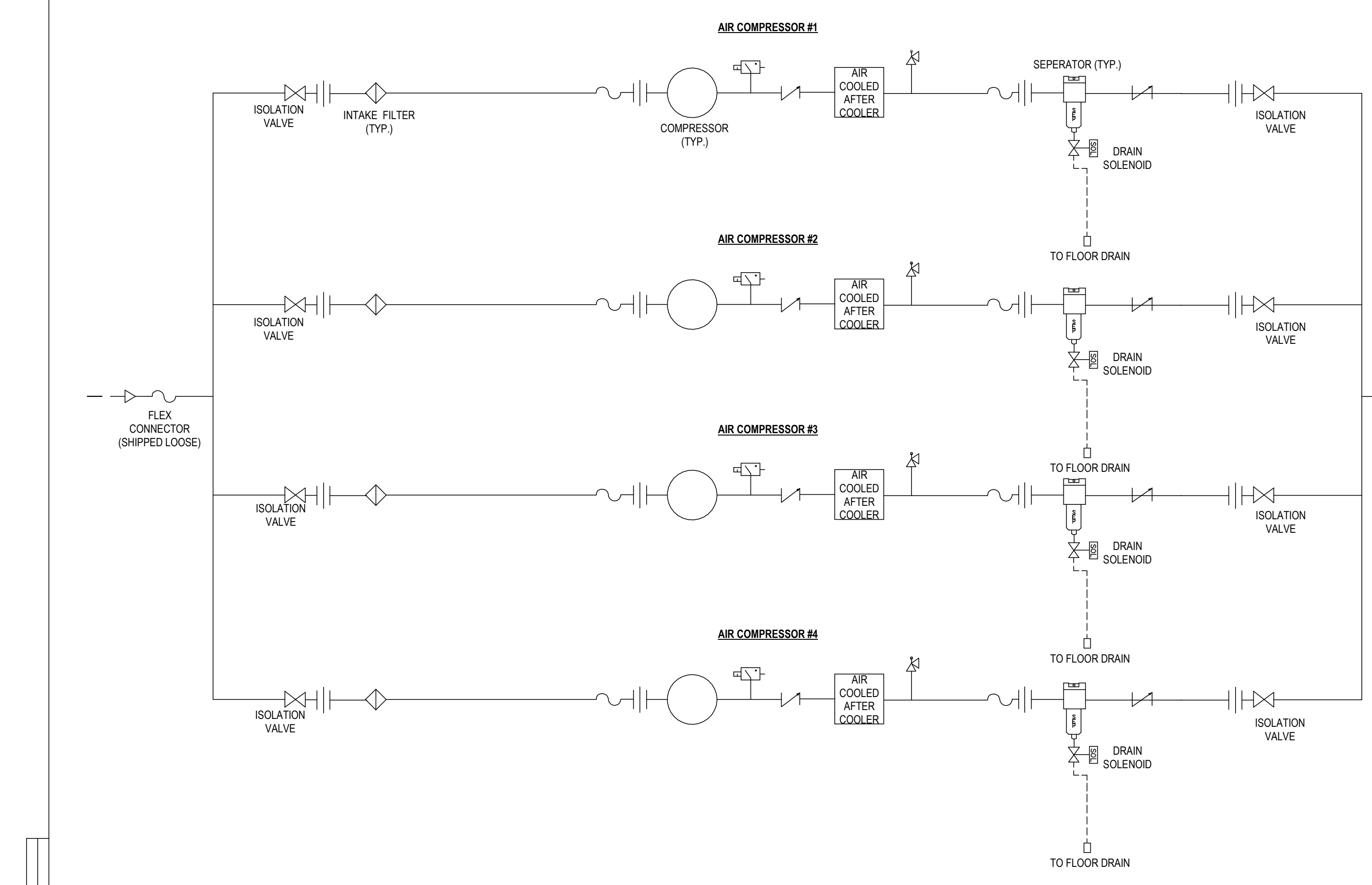

**2** P&ID QUADREPLEX SCROLL AIR SYSTEM WITH DESICCANT AIR DRYERS (2-MAC)  
N.T.S.

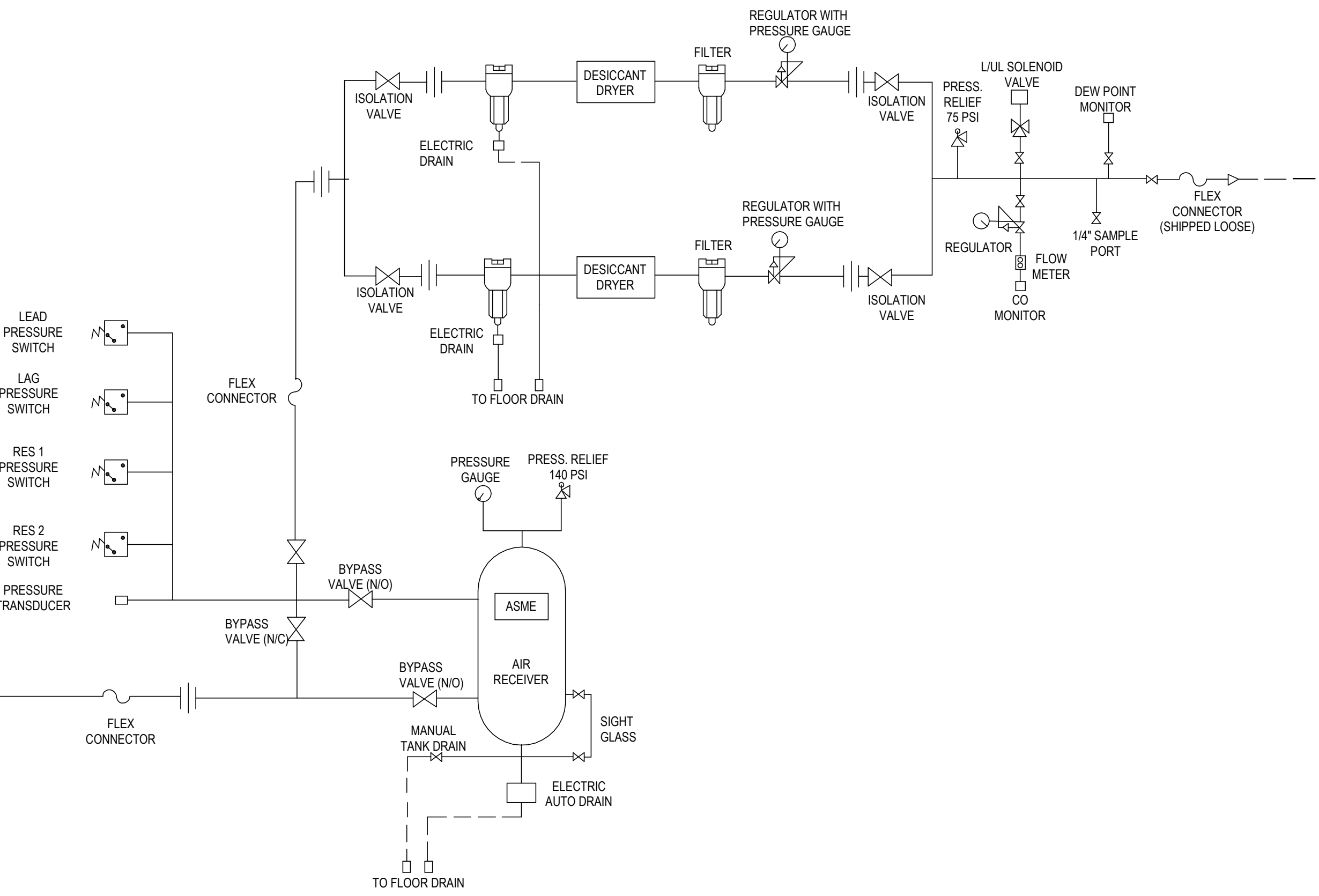

**3** P&ID DUPLEX CONTACTLESS CLAW BY VACUUM (LVS-1)  
N.T.S.

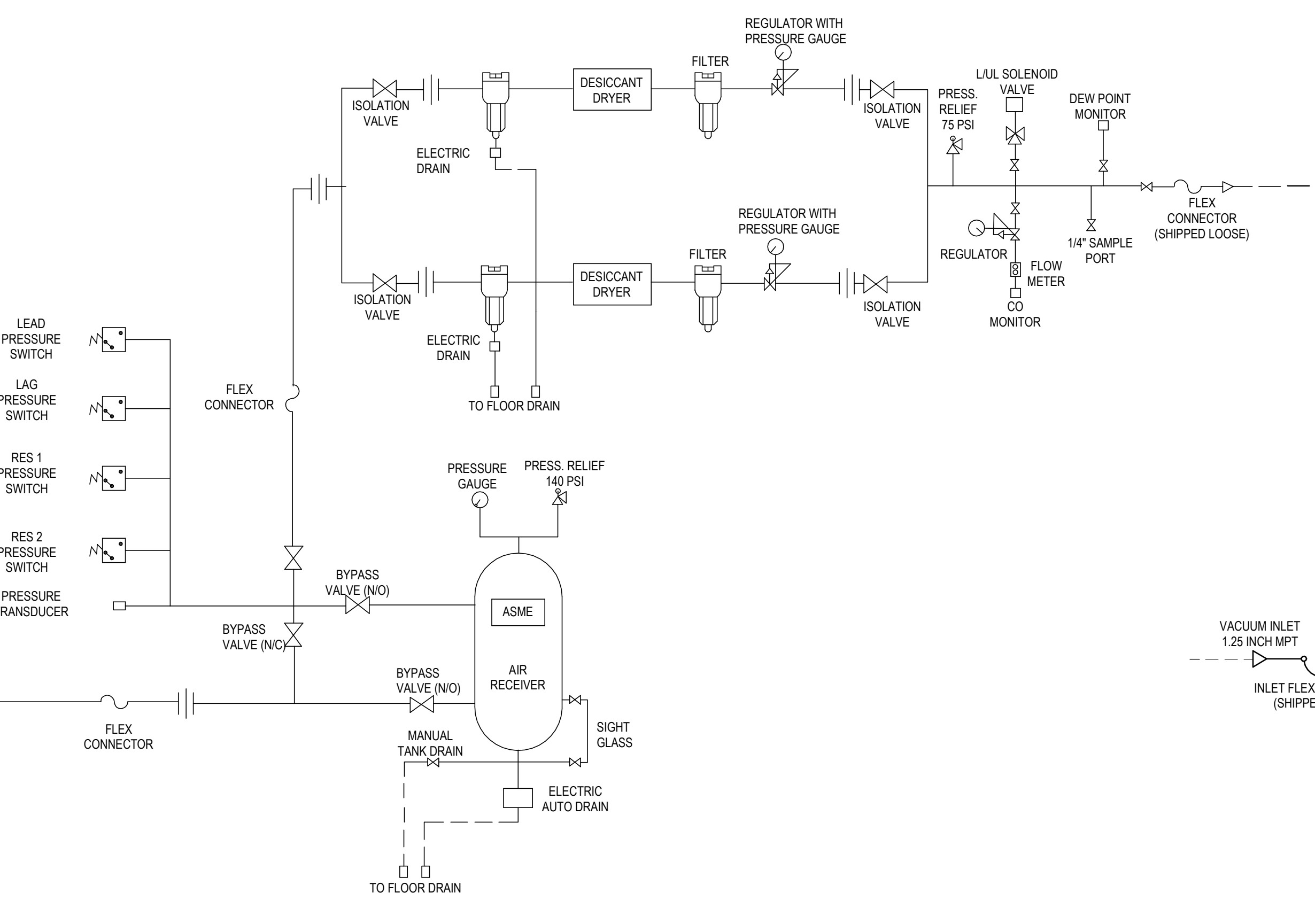

<b>CONSULTANTS:</b> 725 Prudden Street Lansing, MI 48906 - 517.371.1200 123 West Main Street, Suite 200 Gaylord, MI 49735 - 689.732.8131 648 Monroe Avenue NW, Suite 210 Grand Rapids, MI 49503 - 616.454.9414 1211 Ludington Street Escanaba, MI 49829 - 906.233.9360	 elevating human achievement	<b>ARCHITECT/ENGINEERS:</b>  <b>ENGINEERS - SURVEYORS - CONSULTANTS - LANDSCAPE ARCHITECTS - LAND PLANNERS</b>  638 SOUTH GRAND AVE. FOWLERVILLE, MICHIGAN 48836 (OFFICE) 517-223-3512 (FAX) 517-223-9987	<b>REVISIONS:</b> <table border="1" style="width: 100%; border-collapse: collapse;"> <tr><td> </td><td> </td></tr> <tr><td> </td><td> </td></tr> <tr><td> </td><td> </td></tr> <tr><td> </td><td> </td></tr> <tr><td> </td><td> </td></tr> </table>											<b>DRAWING TITLE:</b> <b>MEDICAL GAS DETAILS</b>  DATE: 11-17-2014    BUILDING NUMBER:    PLOT SCALE: As Indicated PROJECT: UPGRADE MEDICAL GAS SYSTEM	VA PROJECT NAME: UPGRADE MEDICAL GAS SYSTEM VA PROJECT NUMBER: 506-14-103 C2AE PROJECT NUMBER: 14-0017 DRAWING NUMBER: <b>P-501</b>

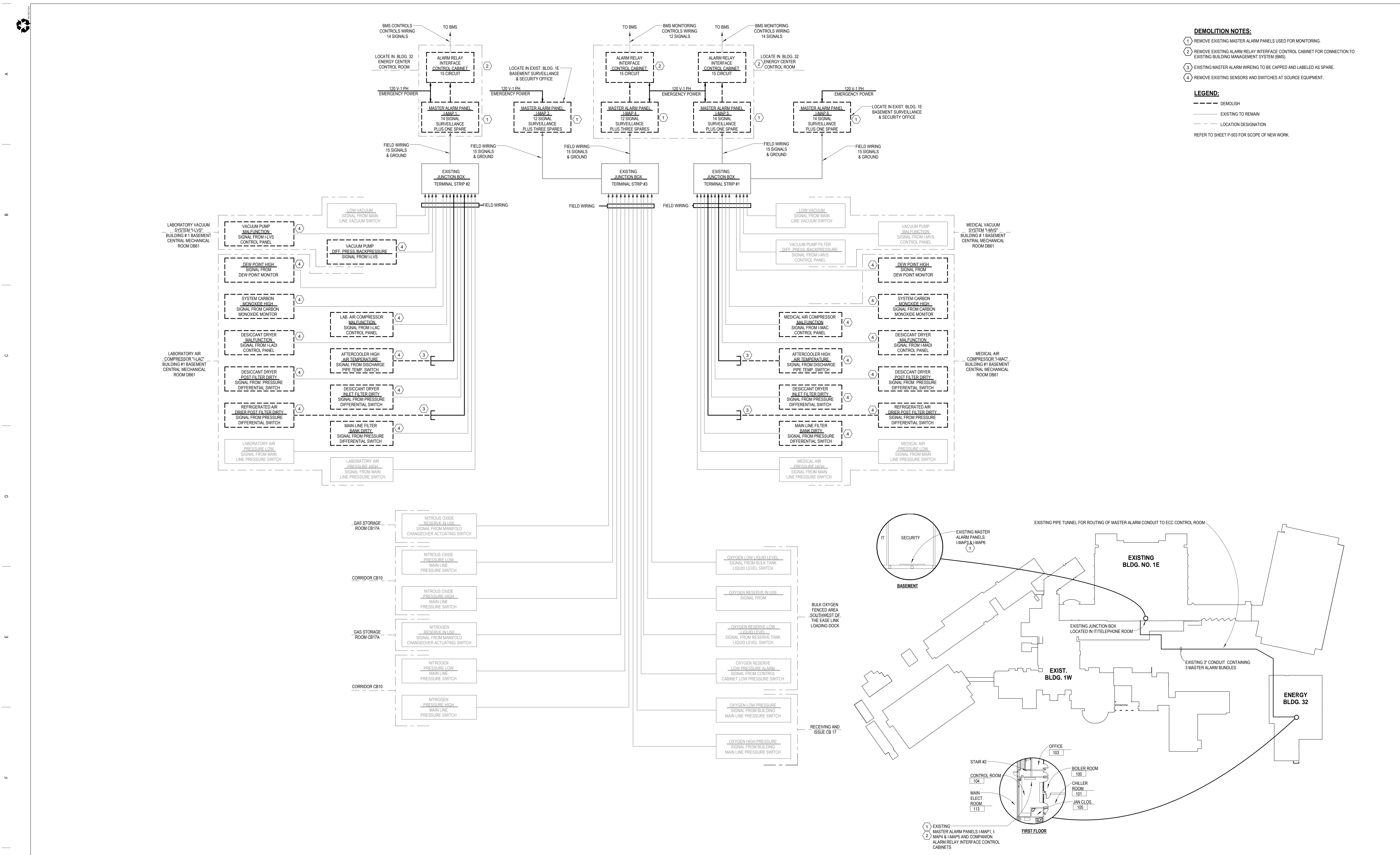

**DEMOLITION NOTES:**

- 1 REMOVE EXISTING MASTER ALARM PANELS USED FOR MONITORING.
- 2 REMOVE EXISTING ALARM RELAY INTERFACE CONTROL CABINET FOR CONNECTION TO EXISTING BUILDING MANAGEMENT SYSTEM (BMS).
- 3 EXISTING MASTER ALARM WIRING TO BE CAPPED AND LABELED AS SPARE.
- 4 REMOVE EXISTING SENSORS AND SWITCHES AT SOURCE EQUIPMENT.

**LEGEND:**

- DEMOLISH
- EXISTING TO REMAIN
- - - LOCATION DESIGNATION

REFER TO SHEET P-503 FOR SCOPE OF NEW WORK.

1 EXISTING MASTER ALARM SCHEMATIC  
N.T.S.

<b>CONSULTANTS:</b> 725 Prudden Street Lansing, MI 48906 - 517.371.1200 123 West Main Street, Suite 200 Gaylord, MI 49735 - 989.732.8131 648 Monroe Avenue NW, Suite 210 Grand Rapids, MI 49503 - 616.454.9414 1211 Ludington Street Escanaba, MI 49829 - 906.233.9380		<b>ARCHITECT/ENGINEERS:</b>  <b>Mountaintop Group Associates, Inc.</b> ENGINEERS - SURVEYORS - CONSULTANTS - LANDSCAPE ARCHITECTS - LAND PLANNERS 638 SOUTH GRAND AVE. FOWLERVILLE, MICHIGAN 48836 (OFFICE) 517-223-3512 (FAX) 517-223-9987		<b>REVISIONS:</b> <table border="1"> <tr><td> </td><td> </td><td> </td></tr> <tr><td> </td><td> </td><td> </td></tr> <tr><td> </td><td> </td><td> </td></tr> <tr><td> </td><td> </td><td> </td></tr> <tr><td> </td><td> </td><td> </td></tr> </table>																<b>DRAWING TITLE:</b> <b>MEDICAL GAS DETAILS</b> DATE: 11-17-2014 BUILDING NUMBER: PLOT SCALE: As Indicated PROJECT: UPGRADE MEDICAL GAS SYSTEM	<b>VA PROJECT NAME:</b> UPGRADE MEDICAL GAS SYSTEM VA PROJECT NUMBER: 506-14-103 C2AE PROJECT NUMBER: 14-0017 DRAWING NUMBER: <b>P-502</b>	<b>DEPARTMENT OF VETERANS AFFAIRS</b> 100% BID DOCUMENTS

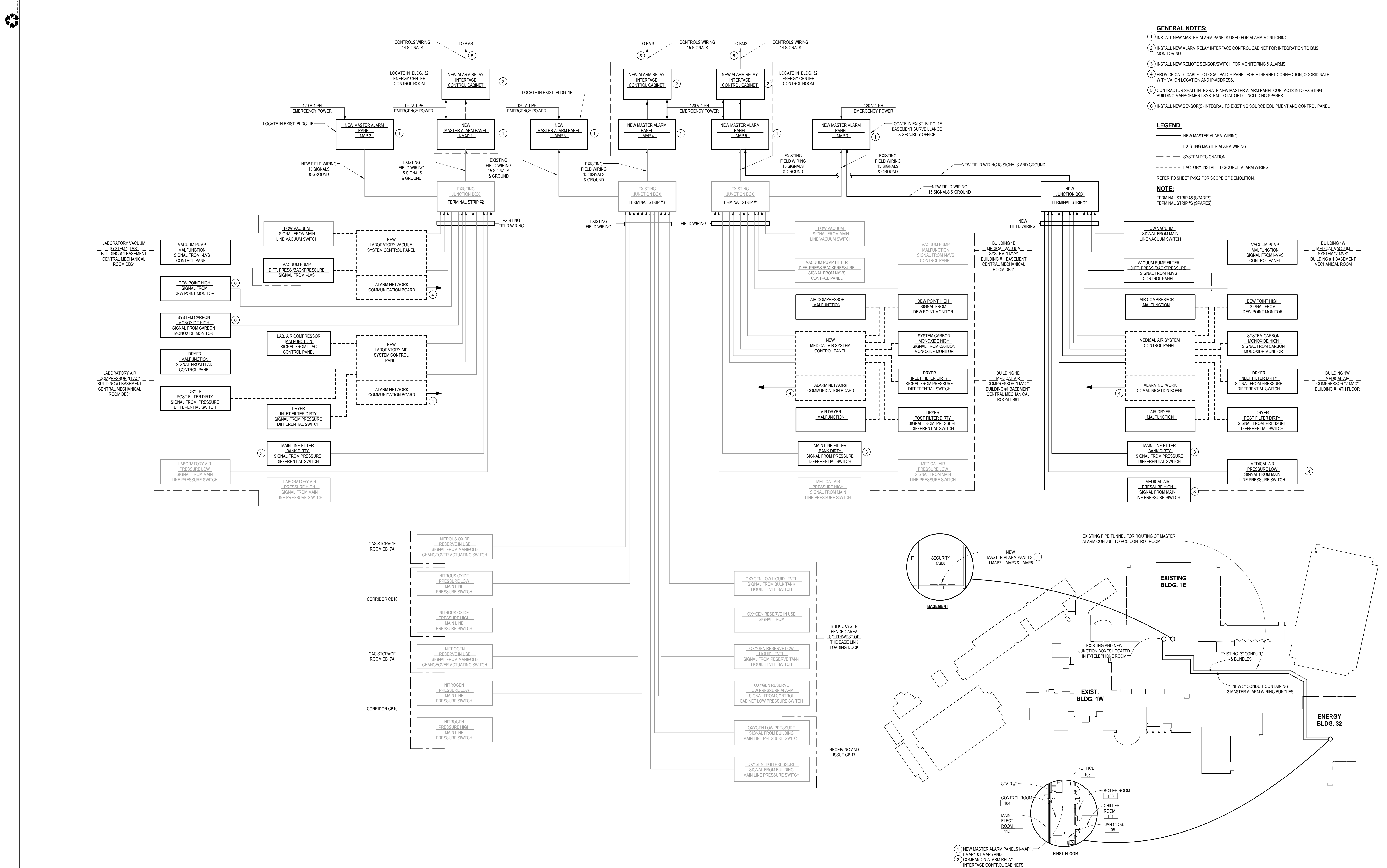

- GENERAL NOTES:**
1. INSTALL NEW MASTER ALARM PANELS USED FOR ALARM MONITORING.
  2. INSTALL NEW ALARM RELAY INTERFACE CONTROL CABINET FOR INTEGRATION TO BMS MONITORING.
  3. INSTALL NEW REMOTE SENSOR/SWITCH FOR MONITORING & ALARMS.
  4. PROVIDE CAT 6 CABLE TO LOCAL PATCH PANEL FOR ETHERNET CONNECTION; COORDINATE WITH VA ON LOCATION AND IP-ADDRESS.
  5. CONTRACTOR SHALL INTEGRATE NEW MASTER ALARM PANEL CONTACTS INTO EXISTING BUILDING MANAGEMENT SYSTEM. TOTAL OF 90, INCLUDING SPARES.
  6. INSTALL NEW SENSOR(S) INTEGRAL TO EXISTING SOURCE EQUIPMENT AND CONTROL PANEL.

- LEGEND:**
- NEW MASTER ALARM WIRING
  - - - EXISTING MASTER ALARM WIRING
  - - - SYSTEM DESIGNATION
  - - - - - FACTORY INSTALLED SOURCE ALARM WIRING
- REFER TO SHEET P-502 FOR SCOPE OF DEMOLITION.
- NOTE:**
- TERMINAL STRIP #5 (SPARES)
  - TERMINAL STRIP #6 (SPARES)

1 NEW MASTER ALARM SCHEMATIC N.T.S.

<b>CONSULTANTS:</b> 725 Prudden Street Lansing, MI 48906 - 517.371.1200 123 West Main Street, Suite 200 Gaylord, MI 49735 - 989.732.8131 648 Monroe Avenue NW, Suite 210 Grand Rapids, MI 49503 - 616.454.9414 1211 Ludington Street Eastland, MI 49829 - 906.233.9380		<b>ARCHITECT/ENGINEERS:</b> ENGINEERS - SURVEYORS - CONSULTANTS - LANDSCAPE ARCHITECTS - LAND PLANNERS  elevating human achievement		<b>REVISIONS:</b> <table border="1"> <tr><td> </td><td> </td><td> </td></tr> <tr><td> </td><td> </td><td> </td></tr> <tr><td> </td><td> </td><td> </td></tr> </table>											<b>DRIVING TITLE:</b> <b>MEDICAL GAS DETAILS</b> DATE: 11-17-2014 BUILDING NUMBER: PLOT SCALE: As Indicated PROJECT: UPGRADE MEDICAL GAS SYSTEM		<b>VA PROJECT NAME:</b> UPGRADE MEDICAL GAS SYSTEM <b>VA PROJECT NUMBER:</b> 506-14-103 <b>C2AE PROJECT NUMBER:</b> 14-0017 <b>DRAWING NUMBER:</b> <b>P-503</b>	
<b>638 SOUTH GRAND AVE.</b> <b>FOWLERVILLE,</b> <b>MICHIGAN 48836</b> <b>(OFFICE) 517-223-3512</b> <b>(FAX) 517-223-9987</b>				<b>STAIR #2</b> CONTROL ROOM 104 MAIN ELECT ROOM 113 OFFICE 103 BOILER ROOM 100 CHILLER ROOM 101 JAN CLOS. 105		<b>VA PROJECT NAME:</b> UPGRADE MEDICAL GAS SYSTEM <b>VA PROJECT NUMBER:</b> 506-14-103 <b>C2AE PROJECT NUMBER:</b> 14-0017 <b>DRAWING NUMBER:</b> <b>P-503</b>												



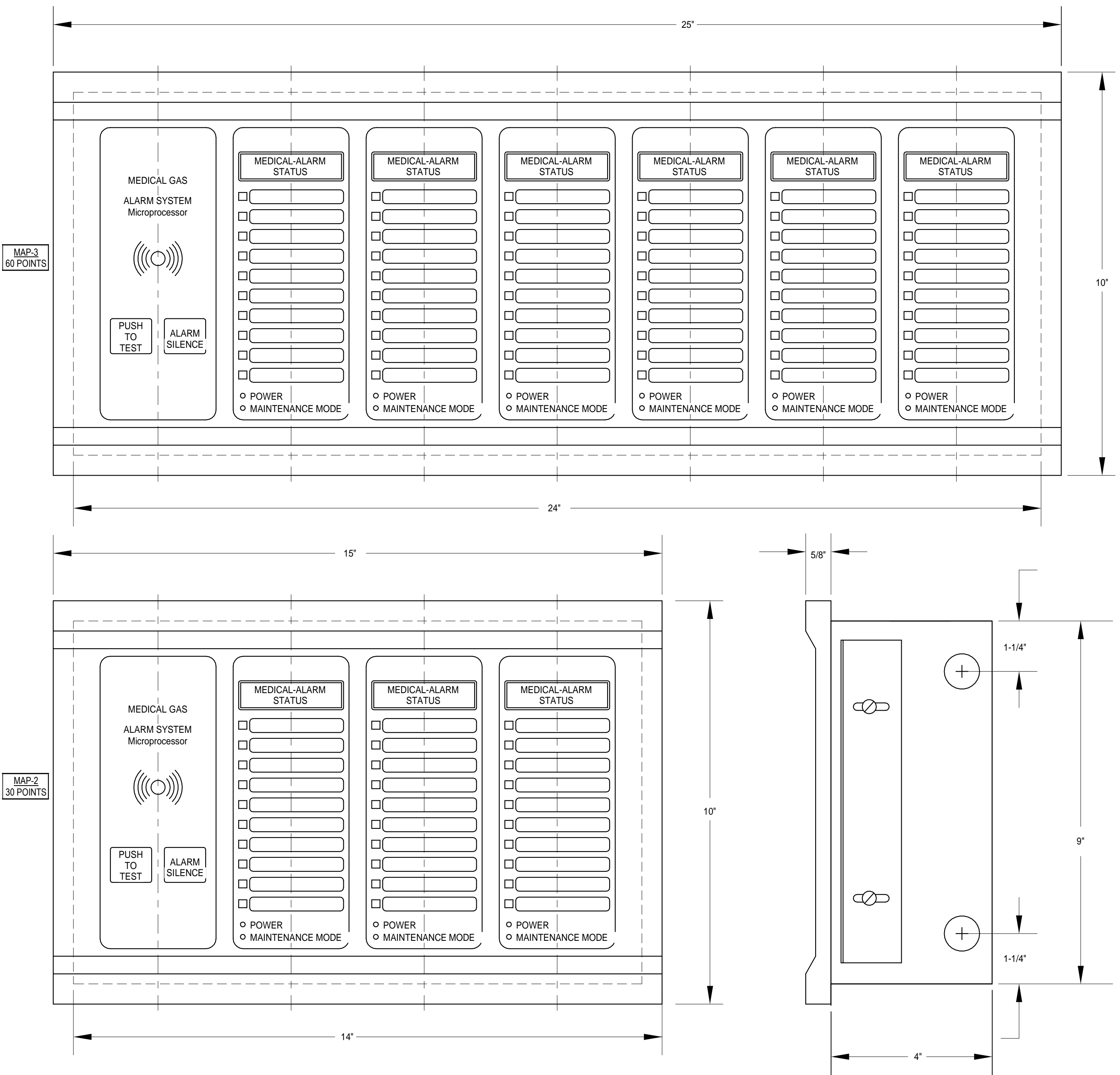

2 MASTER ALARM PANEL DETAIL (SECURITY OFFICE)  
1/4" = 1'-0"

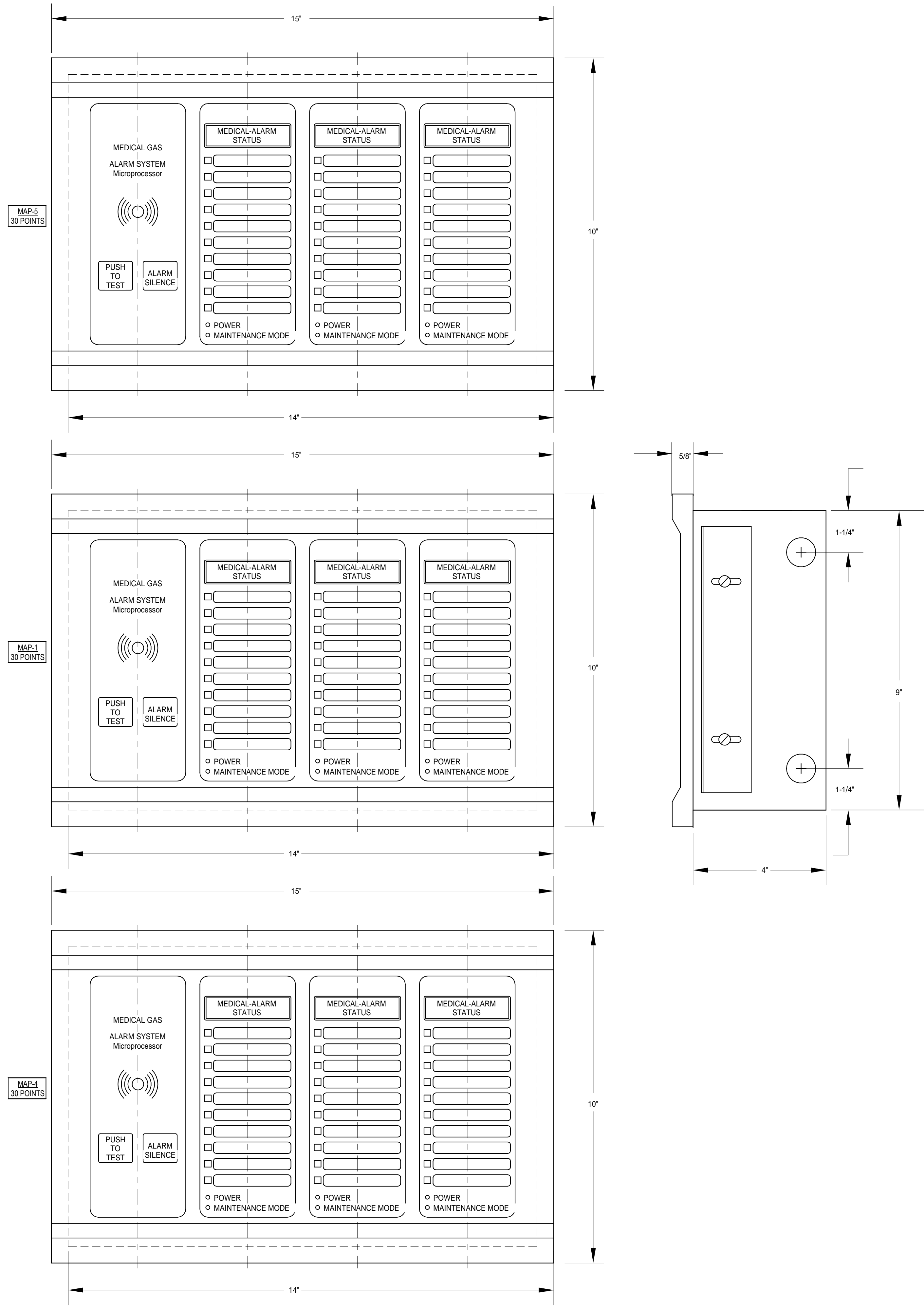

1 MASTER ALARM PANEL DETAIL (ENERGY CENTER)  
1/4" = 1'-0"

<p>CONSULTANTS: 725 Prudden Street Lansing, MI 48906 - 517.371.1200 123 West Main Street, Suite 200 Gaylord, MI 49735 - 989.732.8131 648 Monroe Avenue NW, Suite 210 Grand Rapids, MI 49503 - 616.454.9414 1211 Ludington Street Eastland, MI 49829 - 906.233.9360</p>	 <p>www.c2ae.com elevating human achievement</p>	<p>ARCHITECT/ENGINEERS: ENGINEERS - SURVEYORS - CONSULTANTS - LANDSCAPE ARCHITECTS - LAND PLANNERS</p>  <p>638 SOUTH GRAND AVE. FOWLERVILLE, MICHIGAN 48836 (OFFICE) 517-223-3512 (FAX) 517-223-9987</p>	<p>REVISIONS:</p> <table border="1"> <tr><td> </td><td> </td></tr> <tr><td> </td><td> </td></tr> <tr><td> </td><td> </td></tr> <tr><td> </td><td> </td></tr> <tr><td> </td><td> </td></tr> </table>											<p>DRAWING TITLE: <b>MEDICAL GAS DETAILS</b></p> <p>DATE: 11-17-2014 BUILDING NUMBER:      PLOT SCALE: 1/4" = 1'-0"</p> <p>PROJECT: UPGRADE MEDICAL GAS SYSTEM</p>	<p>VA PROJECT NAME: UPGRADE MEDICAL GAS SYSTEM</p> <p>VA PROJECT NUMBER: 506-14-103</p> <p>C2AE PROJECT NUMBER: 14-0017</p> <p>DRAWING NUMBER: <b>P-504</b></p>

