

EXISTING RADIATOR COVER
PROTECT DURING DEMOLITION
AND CONSTRUCTION.

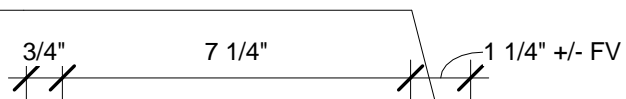

ALUMINUM TRIM BY
CURTAINWALL MANUF.

SEALANT AND BACKER ROD
EACH SIDE. LOCATION PER
MANUFACTURER'S
RECOMMENDATIONS.

STAINLESS STEEL
FLASHING WITH END
DAMS

EPOXY GROUT

CONTINUOUS
CLEAT

TREATED WOOD SHIM

EXISTING BRICK

EXISTING CONCRETE

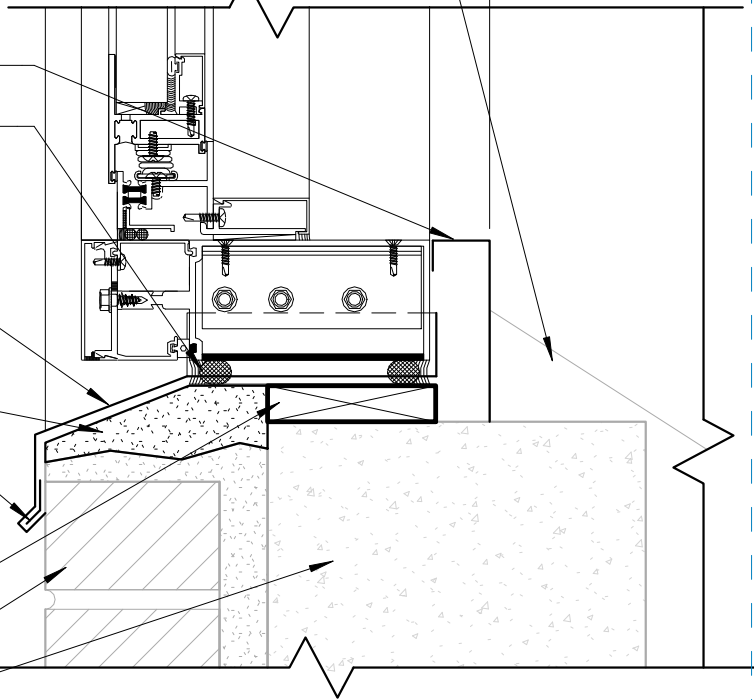

SILL DETAIL @ FLUSH BRICK OPENING
(TYPICAL FOR WINDOW TYPE 1A, 1D, 1E,
1F, 1H, 1G, 1J, 1K, 1X, 7A, 7B, 7C)

D6
3" = 1'-0"