

GENERAL FIRE PROTECTION SYMBOLS

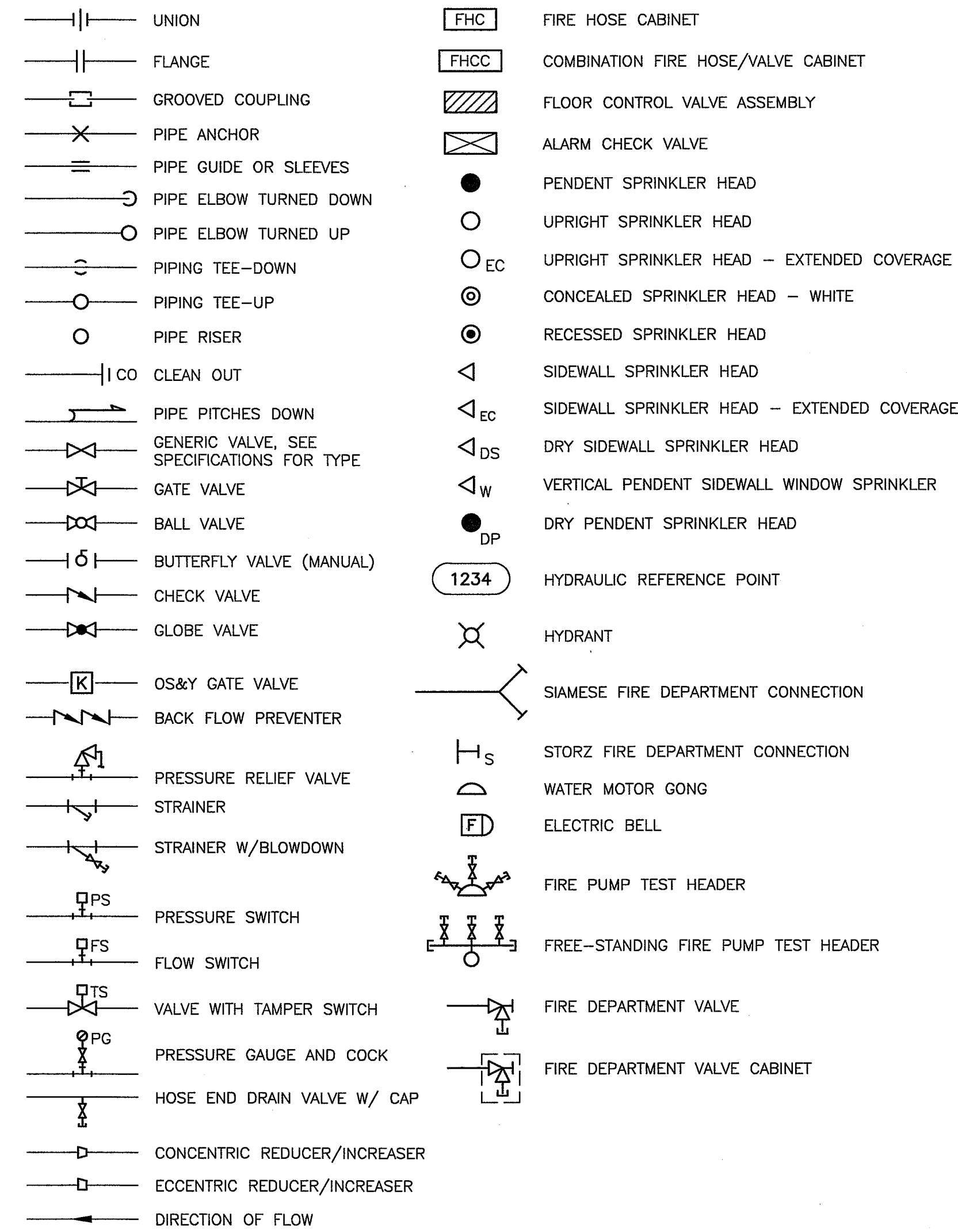

FIRE PROTECTION PIPING SYMBOLS

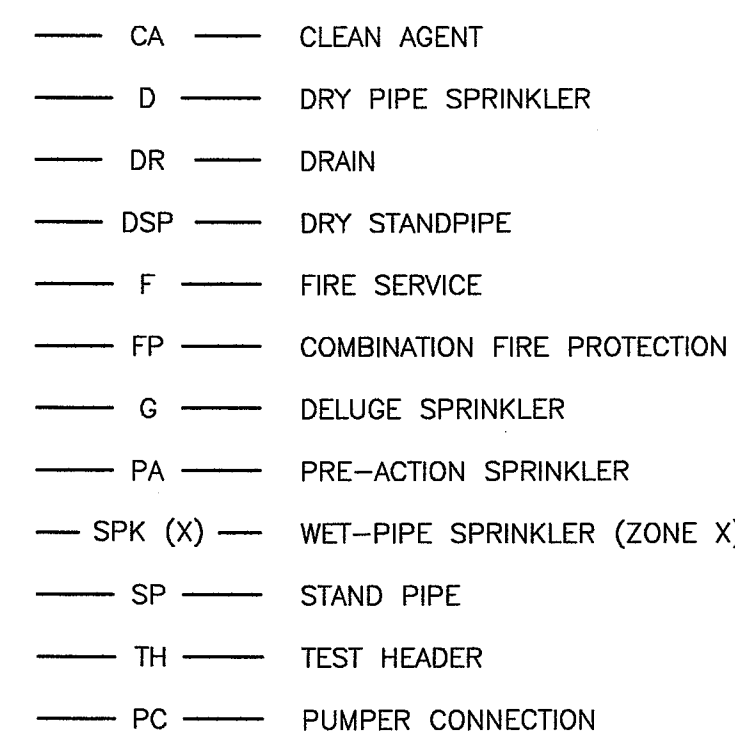

FIRE PROTECTION ABBREVIATIONS

AD	ACCESS DOOR	GC	GENERAL CONTRACTOR
AHJ	AUTHORITY HAVING JURISDICTION	GPM	GALLONS PER MINUTE
AP	ACCESS PANEL	HVAC	HEATING, VENTILATING AND AIR CONDITIONING
BFP	BACKFLOW PREVENTER	ITS	INSPECTOR'S TEST STATION
BLDG	BUILDING	LFPC	LIMIT OF FIRE PROTECTION CONTRACT
BOP	BOTTOM OF PIPE	MAX	MAXIMUM
CA	CLEAN AGENT	MFR	MANUFACTURER
CAFF	CAPPED FOR FUTURE	MIN	MINIMUM
CLG	CEILING	MTD	MOUNTED
CONT	CONTINUATION	NTS	NOT TO SCALE
COORD	COORDINATE	PACV	PRE-ACTION ALARM CHECK VALVE
CTE	CONNECT TO EXISTING	PC	(FIRE DEPARTMENT) PUMPER CONNECTION
CU	COPPER	PIV	POST INDICATING VALVE
CW	COLD WATER	PLBG	PLUMBING
DACV	DRY PIPE ALARM CHECK VALVE	PRV	PRESSURE REDUCING VALVE
DIA	DIAMETER	PS	PRESSURE SWITCH
DIC	DOWN IN CHASE	(R)	REMOVE
DIW	DOWN IN WALL	(REL.)	RELOCATED
DCVA	DOUBLE CHECK VALVE ASSEMBLY	RM	ROOM
DN	DOWN	RPZ	REDUCED PRESSURE ZONE BFP
DR	DRAIN	RV	RELIEF VALVE
DS	DOWNSPOUT	SACV	(WET PIPE) SPRINKLER ALARM CHECK VALVE
DSP	DRY STANDPIPE	SD	SMOKE DETECTOR
DT	DROP AND TRANSITION	SP	STAND PIPE
DWG	DRAWING	SPK	SPRINKLER
ENC	ENCLOSURE	TH	(FIRE DEPARTMENT) TEST HEADER
(E)	EXISTING	TOP	TOP OF PIPE
EXIST.	EXISTING	TS	TAMPER SWITCH
FBO	FURNISHED BY OWNER	TTS	TIGHT TO STEEL
FC	FLEXIBLE CONNECTION	TYP	TYPICAL
FCVA	FLOOR CONTROL VALVE ASSEMBLY	UIC	UP IN CHASE
FDC	FIRE DEPARTMENT CONNECTION	UIW	UP IN WALL
FDV	FIRE DEPARTMENT VALVE	UL	UNDERWRITER'S LABORATORY
FDVC	FIRE DEPARTMENT VALVE CABINET	VCFF	VALVED AND CAPPED FOR FUTURE
FEX	FIRE EXTINGUISHER	W/	WITH
FH	FIRE HOSE	WIV	WALL INDICATING VALVE
FHC	FIRE HOSE CABINET	WMG	WATER MOTOR GONG
FM	FACTORY MUTUAL		
FS	FLOW SWITCH		

FIRE PROTECTION GENERAL NOTES

- ALL PIPING SHALL BE IN ACCORDANCE WITH THE MASSACHUSETTS STATE FIRE MARSHAL OR THESE PLANS WHICH EVER IS MORE STRINGENT.
- CAREFULLY COORDINATE LOCATION OF ALL PIPING WITH THE HEATING AND ELECTRICAL CONTRACTORS AS WELL AS ANY OTHER CONTRACTORS, WHERE CONCURRENT WORK MAY PRESENT POTENTIAL CONFLICTS. IN ADDITION, CAREFULLY COORDINATE PIPING RUNS WITH STRUCTURAL MEMBERS & CONDITIONS, ESPECIALLY IN CONJUNCTION WITH ATTIC FLOOR FRAMING.
- ALL PIPING SHALL RUN CONCEALED ABOVE CEILINGS, IN WALLS AND CHASES OR EXPOSED IN MECHANICAL AREAS, UNLESS NOTED OTHERWISE.
- THE FIRE PROTECTION CONTRACTOR SHALL BE RESPONSIBLE FOR LOCATING ALL PIPE SLEEVES FOR HIS WORK, AS REQUIRED, FOR ALL CONCRETE AND MASONARY WALLS.
- WHERE RUNS OF PIPING PASS ACROSS BUILDING EXPANSION JOINT LOCATIONS, PROVIDE ALLOWANCE FOR MOVEMENT OF BUILDING STRUCTURE TO MEET SEISMIC AREA 2A REQUIREMENTS.
- THE FIRE PROTECTION CONTRACTOR SHALL FURNISH & LOCATE NEEDED ACCESS PANELS TO BE INSTALLED UNDER ANOTHER DIVISION OF THIS CONTRACT.

GENERAL PLUMBING SYMBOLS

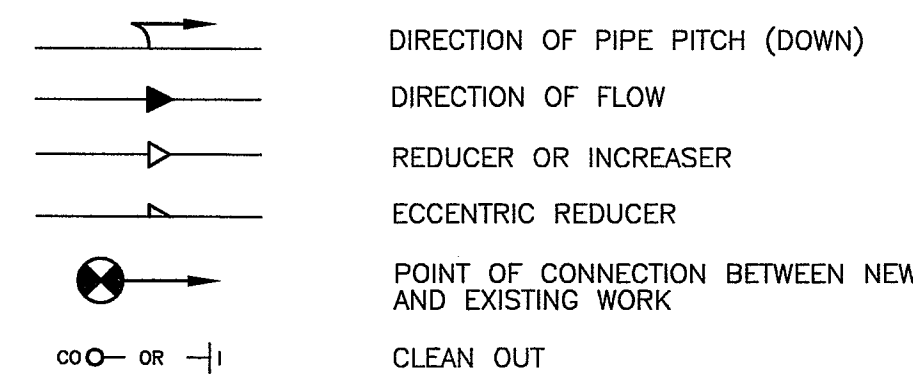

PLUMBING ABBREVIATIONS

A/E	ARCHITECT / ENGINEER
AFF	ABOVE FINISH FLOOR
AFG	ABOVE FINISH GRADE
ASHRAE	AMERICAN SOCIETY HEATING, REFRIGERATION, AIR CONDITIONING ENGINEERS
ASME	AMERICAN SOCIETY MECHANICAL ENGINEERS
ASPE	AMERICAN SOCIETY PLUMBING ENGINEERS
CO	CLEANOUT
DCO	DANDY CLEAN OUT
DWG	DRAWING
FCO	FLOOR CLEANOUT
RD	ROOF DRAIN
RDL	ROOF DRAIN LEADER
RL	ROOF LEADER
RWL	RAIN WATER LEADER
SW	STORM WATER
WCO	WALL CLEANOUT

LIST OF ALTERNATES:

- ITEM 1. GENERAL CONSTRUCTION:** WORK ASSOCIATED WITH BUILDING #3 AND BUILDING #5 TO INSTALL NEW EMERGENCY EGRESS STAIR TOWERS AND SELECT INTERIOR RENOVATIONS REQUIRED TO SUPPORT THE CONNECTION TO SUCH TOWERS. WORK INCLUDES GENERAL CONSTRUCTION, RENOVATIONS, ADDITIONS, ALTERATIONS, HAZARDOUS MATERIAL ABATEMENT, WALKS, GRADING, DRAINAGE, MECHANICAL AND ELECTRICAL WORK, UTILITY SYSTEMS, FIRE PROTECTION, AND SELECT REMOVAL OF EXISTING STRUCTURES AND CONSTRUCTION.
- DEDUCT ALTERNATE NO. 1:** ELIMINATE FIVE (5) STORY STAIR (BLDG 3, STAIR 5) IN ITS ENTIRETY. DO NOT PERFORM ANY DEMOLITION OR RENOVATION RELATED TO THE CONSTRUCTION OF THIS STAIR.
- DEDUCT ALTERNATE NO. 2:** ELIMINATE FIVE (5) STORY STAIR (BLDG 3, STAIR 10) IN ITS ENTIRETY. DO NOT PERFORM ANY DEMOLITION OR RENOVATION RELATED TO THE CONSTRUCTION OF THIS STAIR.
- DEDUCT ALTERNATE NO. 3:** ELIMINATE FIVE (5) STORY STAIR (BLDG 3, STAIR 8) IN ITS ENTIRETY. DO NOT PERFORM ANY DEMOLITION OR RENOVATION RELATED TO THE CONSTRUCTION OF THIS STAIR.
- DEDUCT ALTERNATE NO. 4:** ELIMINATE FIVE (5) STORY STAIR (BLDG 3, STAIR 9) IN ITS ENTIRETY. DO NOT PERFORM ANY DEMOLITION OR RENOVATION RELATED TO THE CONSTRUCTION OF THIS STAIR.
- DEDUCT ALTERNATE NO. 5:** ELIMINATE THREE (3) STORY STAIR (BLDG 5, STAIR 8) IN ITS ENTIRETY. DO NOT PERFORM ANY DEMOLITION OR RENOVATION RELATED TO THE CONSTRUCTION OF THIS STAIR.

DRAIN SCHEDULE

TAG	APPLICATION	TYPICAL UNIT MFG & MODEL NO.	DESCRIPTION	NOTES
RD-A	ROOF DRAIN	ZURN ZA-100-DP	15"Ø ROOF DRAIN, ALUMINUM DOME, "TOP SET" DECK PLATE	①②

NOTES: ① EXPANSION JOINT - REQUIRED WHERE PIPING CONNECTION TO THE DRAIN DOES NOT IMMEDIATELY OFFSET TO THE HORIZONTAL AND RUN MORE THAN 5 FEET. PROVIDE ZURN #Z-190.
② REFER TO ARCHITECTURAL ROOF PLAN FOR ROOF DRAIN LOCATIONS.

GENERAL NOTE

- ALL GENERAL NOTES, SYMBOL LISTS, AND DETAILS ARE TO BE CONSIDERED AS APPLICABLE TO ALL PLUMBING/FIRE PROTECTION DRAWINGS FOR THIS PROJECT. SYMBOLS AND ABBREVIATIONS SHOWN ON THIS SHEET ARE FOR REFERENCE ONLY AND DO NOT INDICATE THEIR INCORPORATION IN THE DESIGN.

100% CONSTRUCTION DOCUMENT SUBMISSION
20-JUNE-2014
FULLY SPRINKLERED

CONSULTANTS:

ARCHITECT/ENGINEERS:

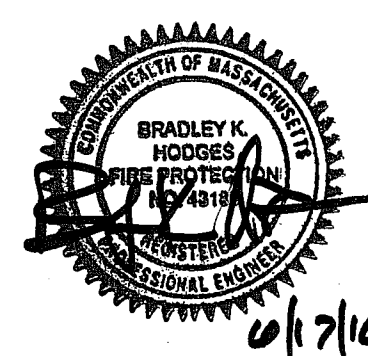

ARCHITECTURE One Dundee Park Suite 4
Andover, Massachusetts 01810
ENGINEERING tel. (207) 772-3846
PLANNING fax. (207) 772-1070
INTERIORS www.smrinc.com
ENERGY SMRT Project Number - 13006

Drawing Title
PLUMBING AND FIRE PROTECTION LEGEND, ABBREVIATIONS AND SCHEDULES

Approved Project Director
VAPAHCS PLANNING AND ENGINEERING

Project Title
VAMC BROCKTON LIFE SAFETY RENOVATIONS

Location
BROCKTON MA

Date
20-JUNE-2014

Project Number
523-395

Building Number
5

Drawing Number
05.FP001

Dwg. 280 of 310

Office of Construction and Facilities Management



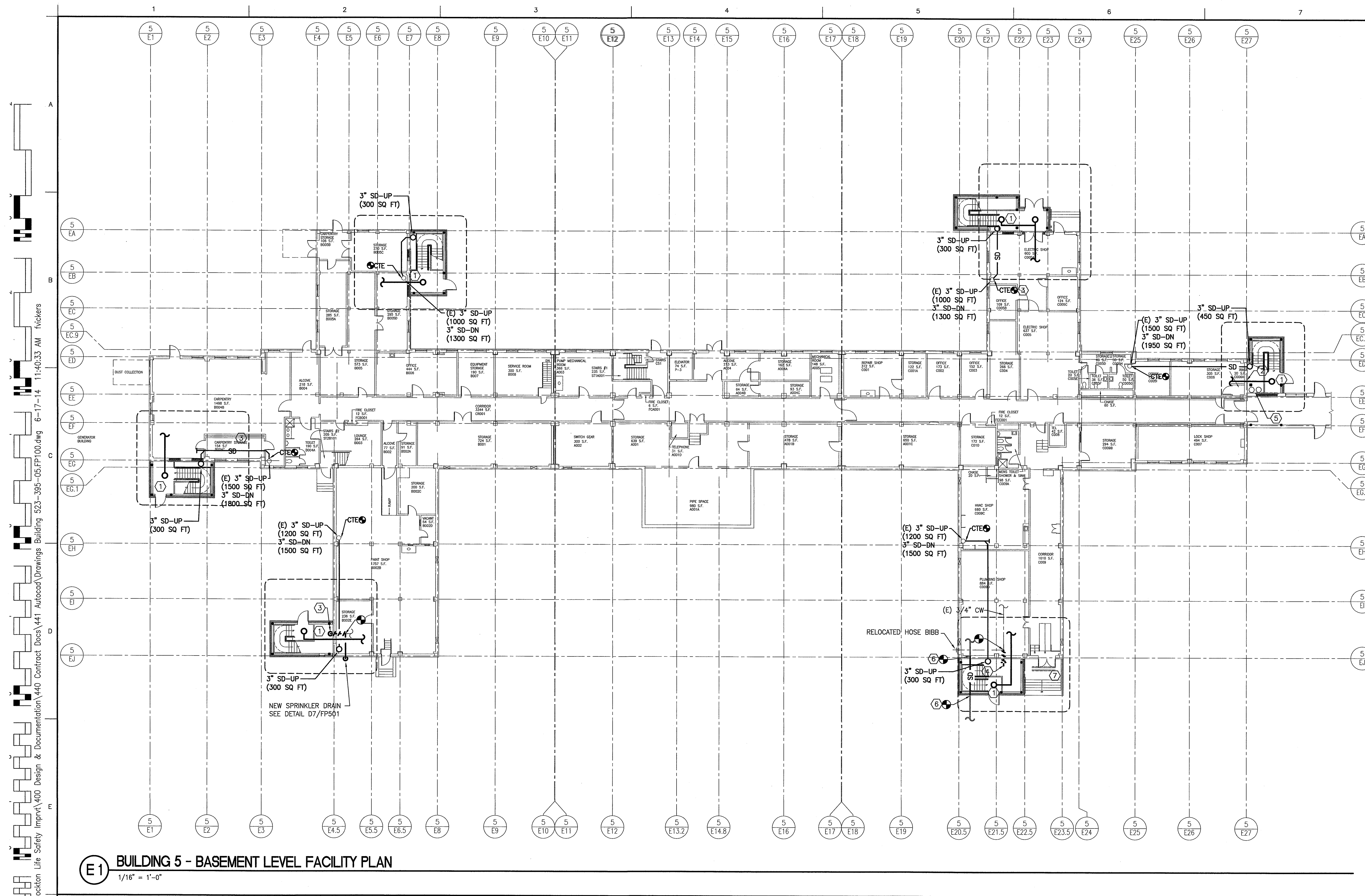

NOTES:
 1. SEE SHEET FP001 FOR LEGEND AND ABBREVIATIONS.

- KEYED NOTES:**
- EXTEND EXISTING SPRINKLER SYSTEM TO PROVIDE COVERAGE UNDER FIRST ACCESSIBLE LANDING ABOVE THE BOTTOM OF SHAFT.
 - PROVIDE WITH EXPANSION FITTING SIMILAR TO 'METRAFLEX FIRELOOP' AT BUILDING EXPANSION JOINT.
 - RELOCATE EXISTING SPRINKLER DRAIN TO SOUTH SIDE OF BUILDING.
 - RELOCATE EXISTING HOSE BIBB TO WEST SIDE OF BUILDING. CONTRACTOR TO DETERMINE IF EXISTING HOSE BIBB IS IN WORKING ORDER. IF NOT IN WORKING ORDER CONTRACTOR TO REPLACE WITH SIMILAR HOSE BIBB.
 - RELOCATE EXISTING CLEAN OUTS OUTSIDE OF NEW STAIR WELL.
 - EXISTING SECTION OF 8" STORM PIPING TO BE REPLACED. COORDINATE WITH STRUCTURAL FOR SLEEVING THROUGH STAIR TOWER AND COORDINATE EXISTING INVERT ELEVATION WITH CIVIL.
 - REMOVE EXISTING TRENCH DRAIN. CONNECT NEW FLOOR DRAIN (ZURN #ZN526-HP-S, OR ENGINEER APPROVED EQUAL) TO EXISTING PIPING BELOW SLAB.

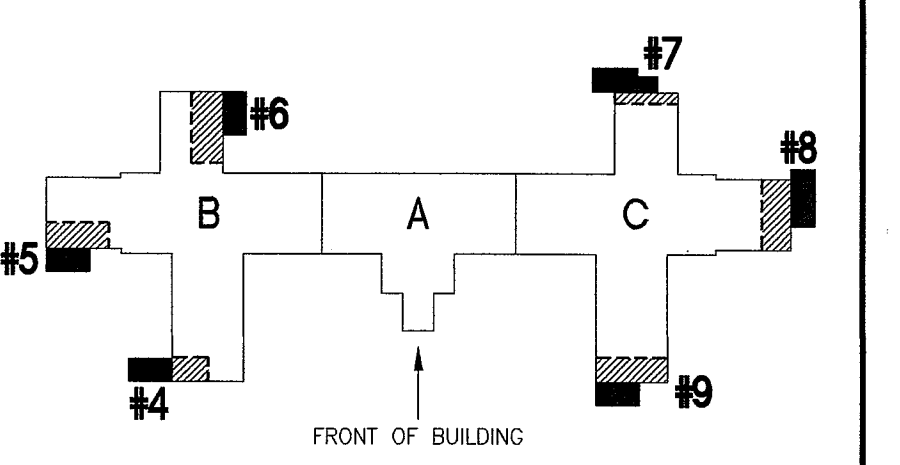

D7 KEY PLAN - BLDG 5
 N.T.S.

E1 BUILDING 5 - BASEMENT LEVEL FACILITY PLAN
 1/16" = 1'-0"

100% CONSTRUCTION DOCUMENT SUBMISSION
 20-JUNE-2014
 FULLY SPRINKLERED

K:\2013 Projects\13006_VAMC Brockton Life Safety Imprv\400 Design & Documentation\441 Autocad Drawings Building 523-395-05.FP100.dwg 6-17-14 11:40:33 AM Ivickers
 VIA FORM 08-6231

CONSULTANTS: 		ARCHITECT/ENGINEERS: ARCHITECTURE One Dundee Park Suite 4 Andover, Massachusetts 01810 ENGINEERING tel. (207) 772-3846 PLANNING fax. (207) 772-1070 INTERIORS www.smrinc.com ENERGY SMRT Project Number - 13006		Drawing Title BUILDING 5 BASEMENT LEVEL - PLUMBING AND FIRE PROTECTION PLAN Approved Project Director VAPAHCS PLANNING AND ENGINEERING		Project Title VAMC BROCKTON LIFE SAFETY RENOVATIONS Location BROCKTON MA Date 20-JUNE-2014 Checked BKH Draw KDD		Project Number 523-395 Building Number 5 Drawing Number 05.FP100 Dwg. 281 of 310		Office of Construction and Facilities Management Department of Veterans Affairs	
Revisions: 0 100% CONSTRUCTION DOCUMENT SUBMISSION 20-JUNE-2014 Date											

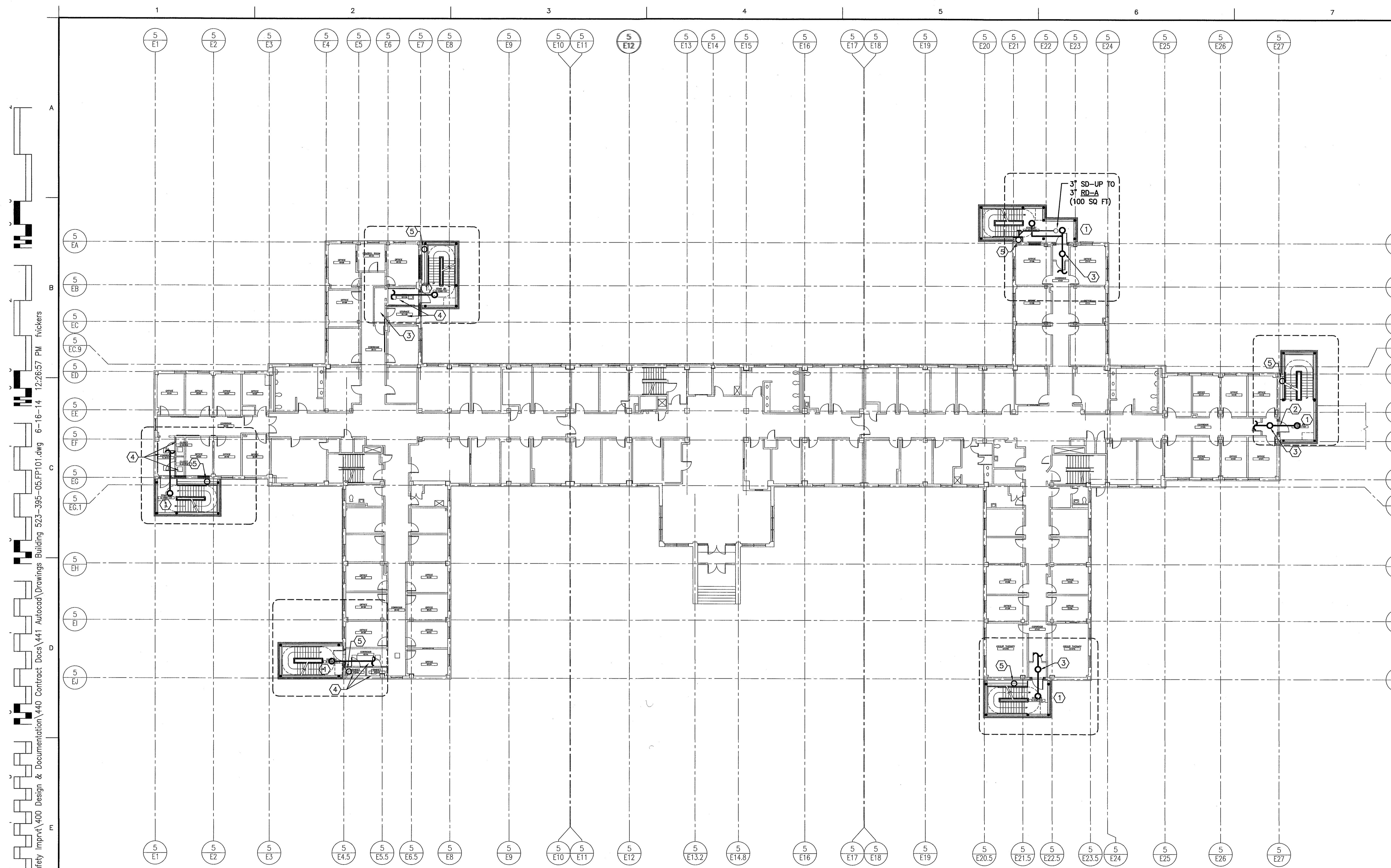

NOTES:
 1. SEE SHEET FP001 FOR LEGEND AND ABBREVIATIONS.

- KEYED NOTES:**
- ① EXTEND EXISTING SPRINKLER SYSTEM TO PROVIDE COVERAGE UNDER EACH ACCESSIBLE LANDING.
 - ② PROVIDE WITH EXPANSION FITTING SIMILAR TO 'METRAFLEX FIRELOOP' AT BUILDING EXPANSION JOINT.
 - ③ PROVIDE TEMPORARY SPRINKLER COVERAGE IN TEMPORARY VESTIBULE DURING CONSTRUCTION
 - ④ REWORK EXISTING SPRINKLER COVERAGE AS REQUIRED TO PROVIDE COMPLETE COVERAGE FOR NEW ARCHITECTURAL LAYOUT. PER NFPA 13.
 - ⑤ 3" SD UP & DN.

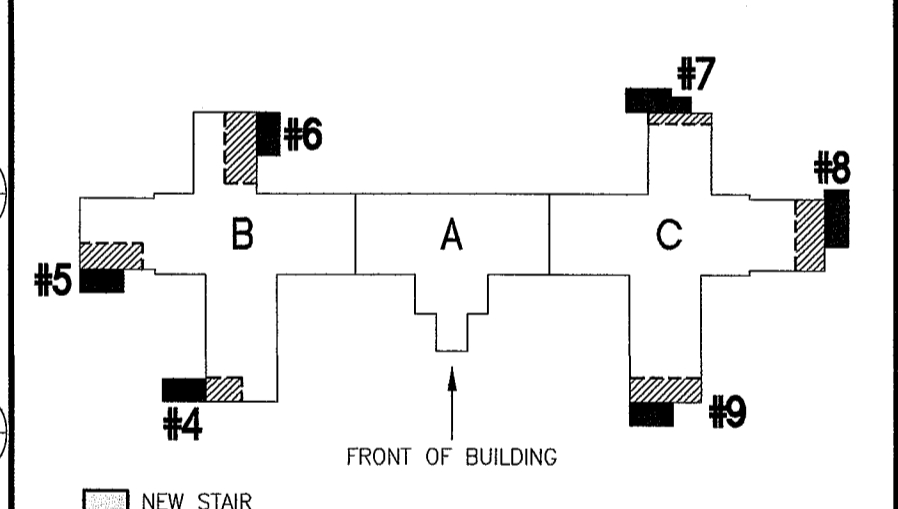

D7 KEY PLAN - BLDG 5
 N.T.S.

E1 BUILDING 5 - FIRST LEVEL FACILITY PLAN
 1/16" = 1'-0"

100% CONSTRUCTION
 DOCUMENT SUBMISSION
 20-JUNE-2014
 FULLY SPRINKLERED

K:\2013 Projects\13006_VAMC Brockton Life Safety Imprvx\400 Design & Documentation\440 Contract Docs\441 Autocad Drawings Building 523-395-05.FP101.dwg 6-16-14 12:26:57 PM Ivickers
 VA FORM 08-6231

Revision	Description	Date
0	100% CONSTRUCTION DOCUMENT SUBMISSION	20-JUNE-2014

CONSULTANTS:

ARCHITECT/ENGINEERS:

ARCHITECTURE
 ENGINEERING
 PLANNING
 INTERIORS
 ENERGY

One Dundee Park Suite 4
 Andover, Massachusetts 01810
 tel. (207) 772-3846
 fax. (207) 772-1070
 www.smrinc.com

SMRT
 SMRT Project Number - 13006

Drawing Title
 BUILDING 5
 FIRST LEVEL - PLUMBING AND
 FIRE PROTECTION PLAN

Approved: Project Director

VAPAHCS PLANNING AND ENGINEERING

Project Title
 VAMC BROCKTON
 LIFE SAFETY RENOVATIONS

Location
 BROCKTON MA

Date
 20-JUNE-2014

Checked
 BKH

Drawn
 KDD

Project Number
 523-395

Building Number
 5

Drawing Number
 05.FP101

Dwg. 282 of 310

**Office of
 Construction
 and Facilities
 Management**

Department of
 Veterans Affairs

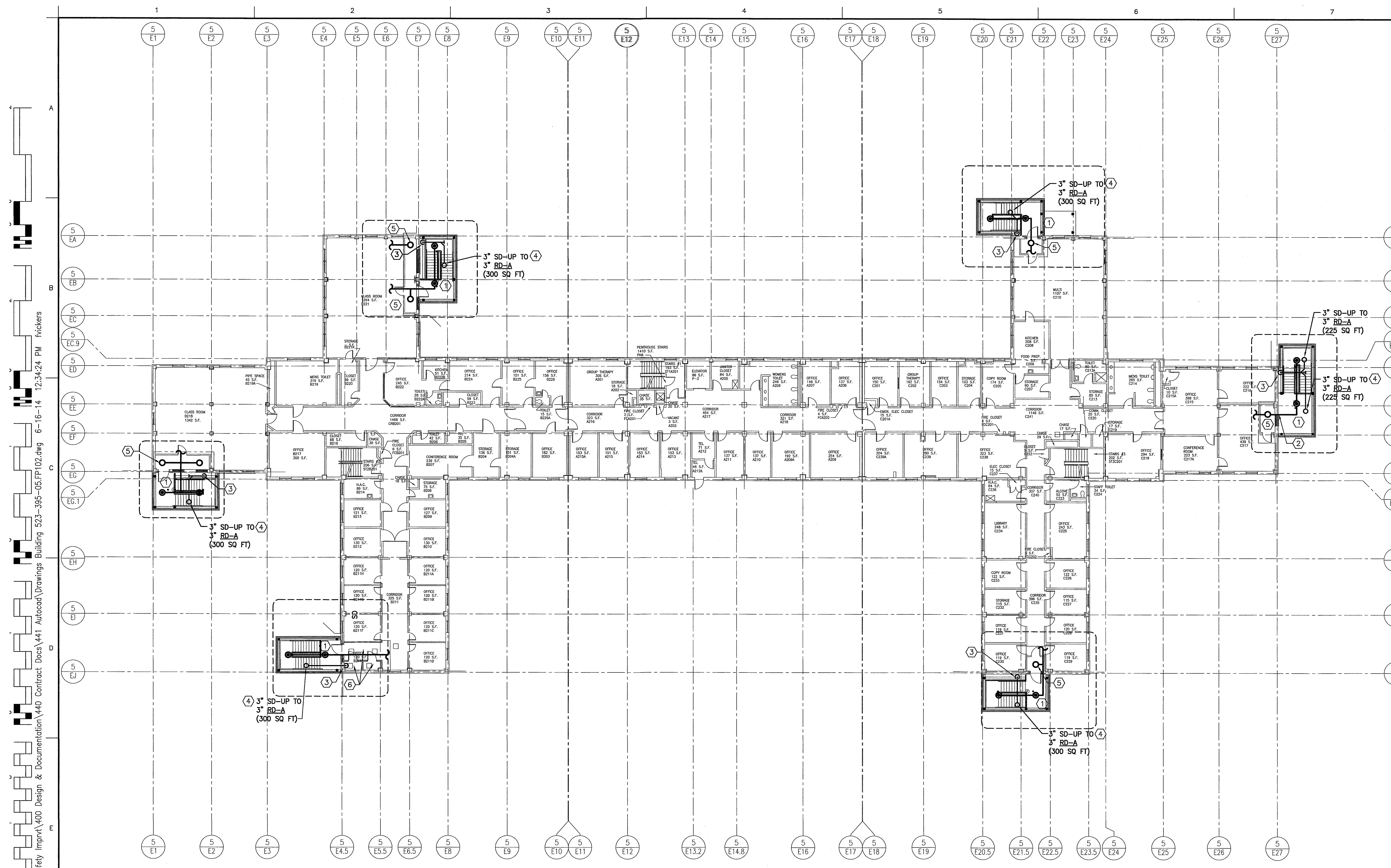

NOTES:
 1. SEE SHEET FP001 FOR LEGEND AND ABBREVIATIONS.

- KEYED NOTES:**
- ① EXTEND EXISTING SPRINKLER SYSTEM TO PROVIDE COVERAGE AT TOP OF STAIRWELL.
 - ② PROVIDE WITH EXPANSION FITTING SIMILAR TO 'METRAFLEX FIRELOOP' AT BUILDING EXPANSION JOINT.
 - ③ EXTEND 3" SD PIPING DOWN AND CONNECT AT LOWER LEVEL
 - ④ COORDINATE EXACT LOCATION OF ROOF DRAIN WITH ARCHITECTURAL DRAWINGS.
 - ⑤ PROVIDE TEMPORARY SPRINKLER COVERAGE IN TEMPORARY VESTIBULE DURING CONSTRUCTION.
 - ⑥ REWORK EXISTING SPRINKLER COVERAGE AS REQUIRED TO PROVIDE COMPLETE COVERAGE FOR NEW ARCHITECTURAL LAYOUT. PER NFPA 13.

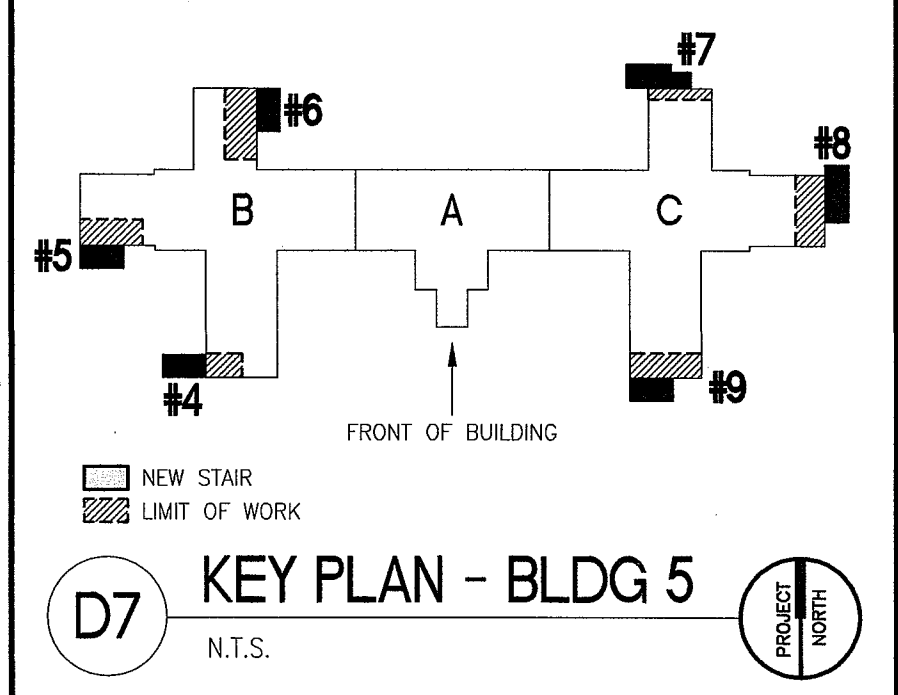

E1 BUILDING 5 - SECOND LEVEL FIRE PROTECTION PLAN
 1/16" = 1'-0"

100% CONSTRUCTION DOCUMENT SUBMISSION
 20-JUNE-2014
 FULLY SPRINKLERED

K:\2013 Projects\13006_VAMC Brockton Life Safety Imprvt\400 Design & Documentation\440 Contract Docs\441 Autocad Drawings Building 523-395-05.FP102.dwg 6-16-14 12:34:24 PM Nickers
 VA FORM DB-6231

CONSULTANTS: 		ARCHITECT/ENGINEERS: ARCHITECTURE One Dundee Park Suite 4 Andover, Massachusetts 01810 ENGINEERING tel. (207) 772-3846 PLANNING fax. (207) 772-1070 INTERIORS www.smrtinc.com ENERGY SMRT Project Number - 13006		Drawing Title BUILDING 5 SECOND LEVEL PLUMBING AND FIRE PROTECTION PLAN Approved Project Director VAPAHCS PLANNING AND ENGINEERING		Project Title VAMC BROCKTON LIFE SAFETY RENOVATIONS Location BROCKTON MA		Project Number 523-395 Building Number 5 Drawing Number 05.FP102 Dwg. 283 of 310		Office of Construction and Facilities Management Department of Veterans Affairs	
Revisions: 0 100% CONSTRUCTION DOCUMENT SUBMISSION 20-JUNE-2014 Date						Date 20-JUNE-2014 Checked BKH Drawn KDD					

K:\2013 Projects\13006_VAMC Brockton Life Safety Improv\400 Design & Documentation\440 Contract Docs\441 Autocad Drawings Building 523-395-05.FP501.dwg 6-16-14 12:45:00 PM ivickers
 VA FORM 08-6231

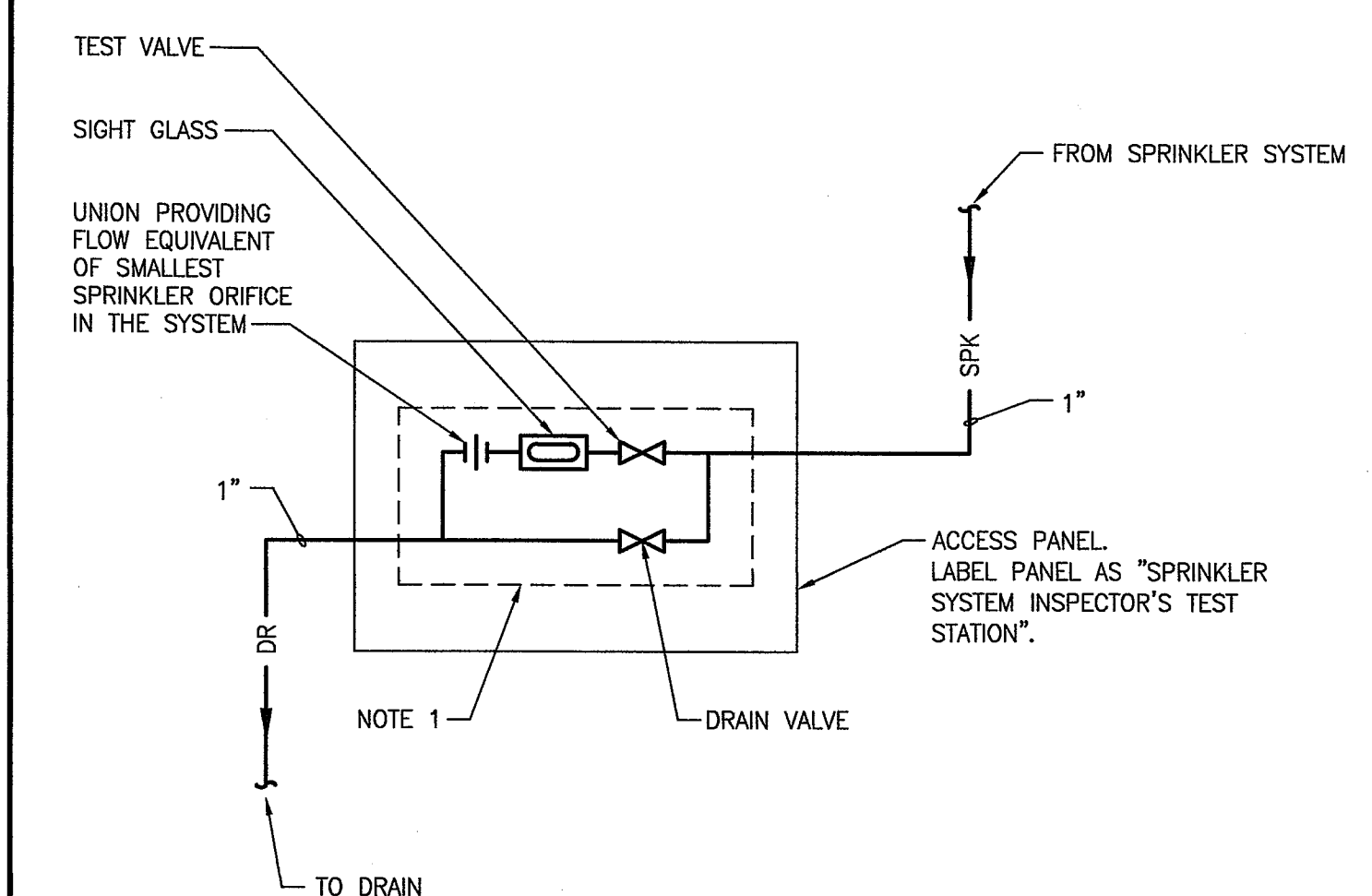

NOTES:
 1. COMBINATION DRAIN AND TEST VALVE IS ACCEPTABLE IN LIEU OF INDIVIDUAL COMPONENTS, VICTAULIC STYLE 718 OR EQUAL.

B5 INSPECTORS TEST STATION (ITS)
NTS

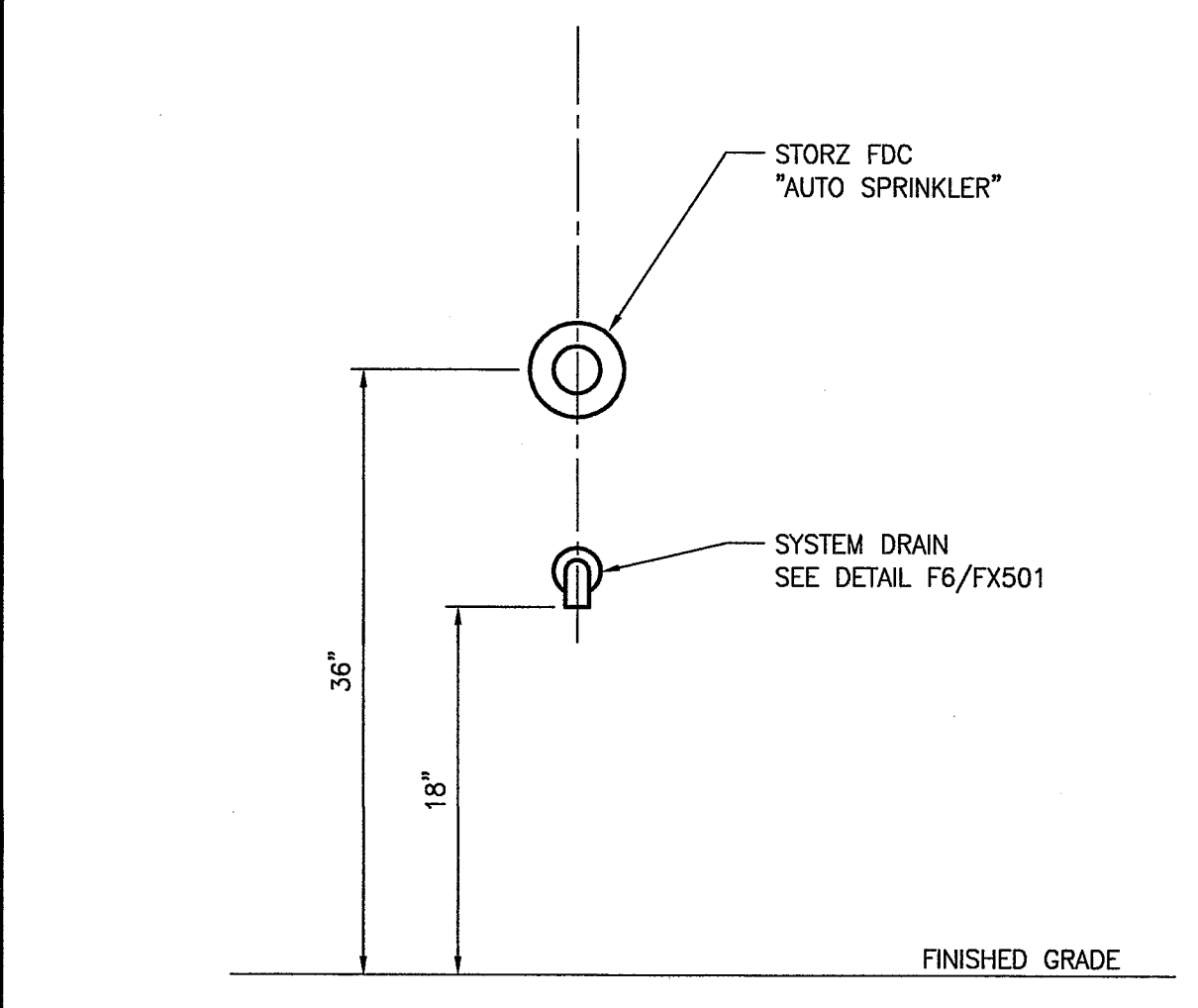

B7 FIRE APPURTENANCE ELEVATIONS
NTS

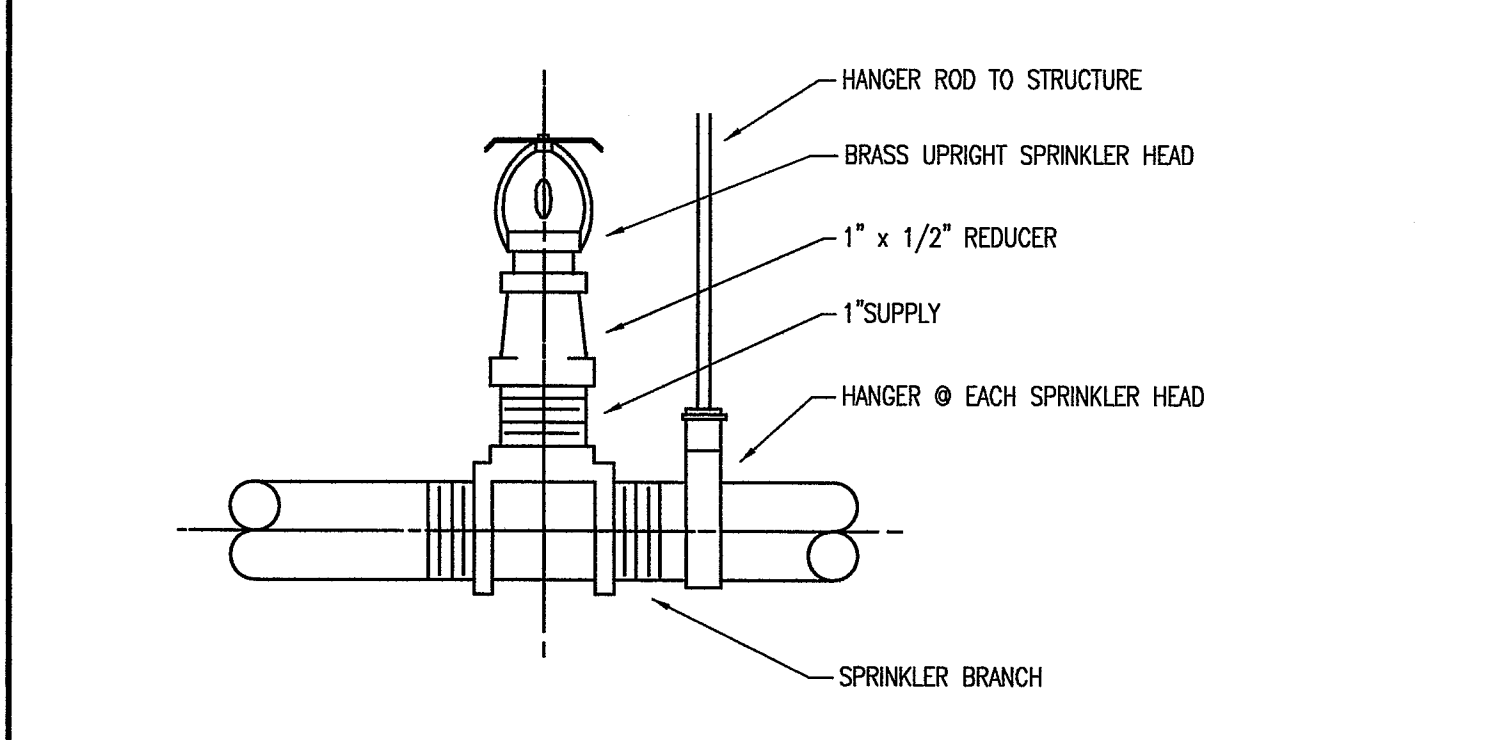
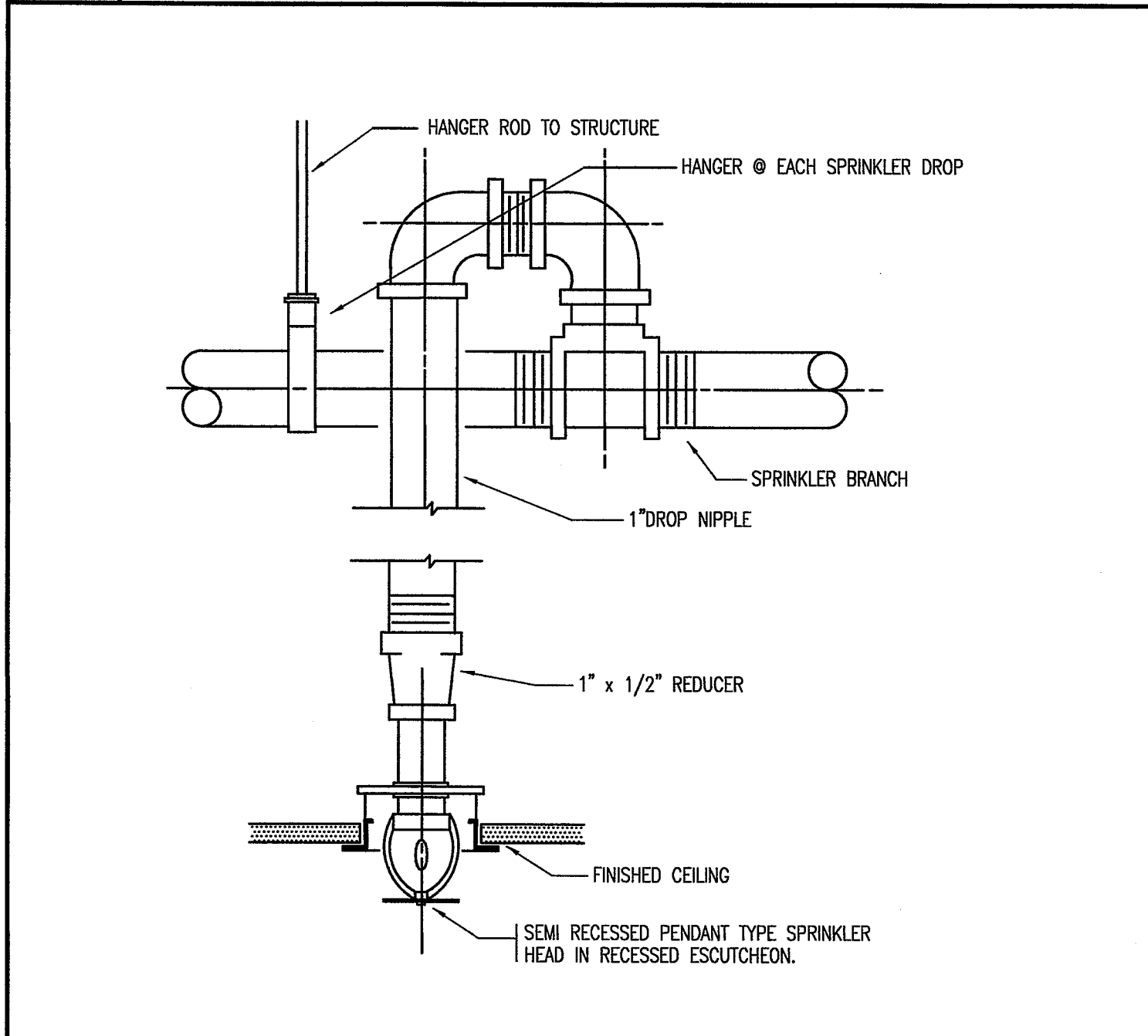

E5 TYPICAL SPRINKLER INSTALLATION
NTS

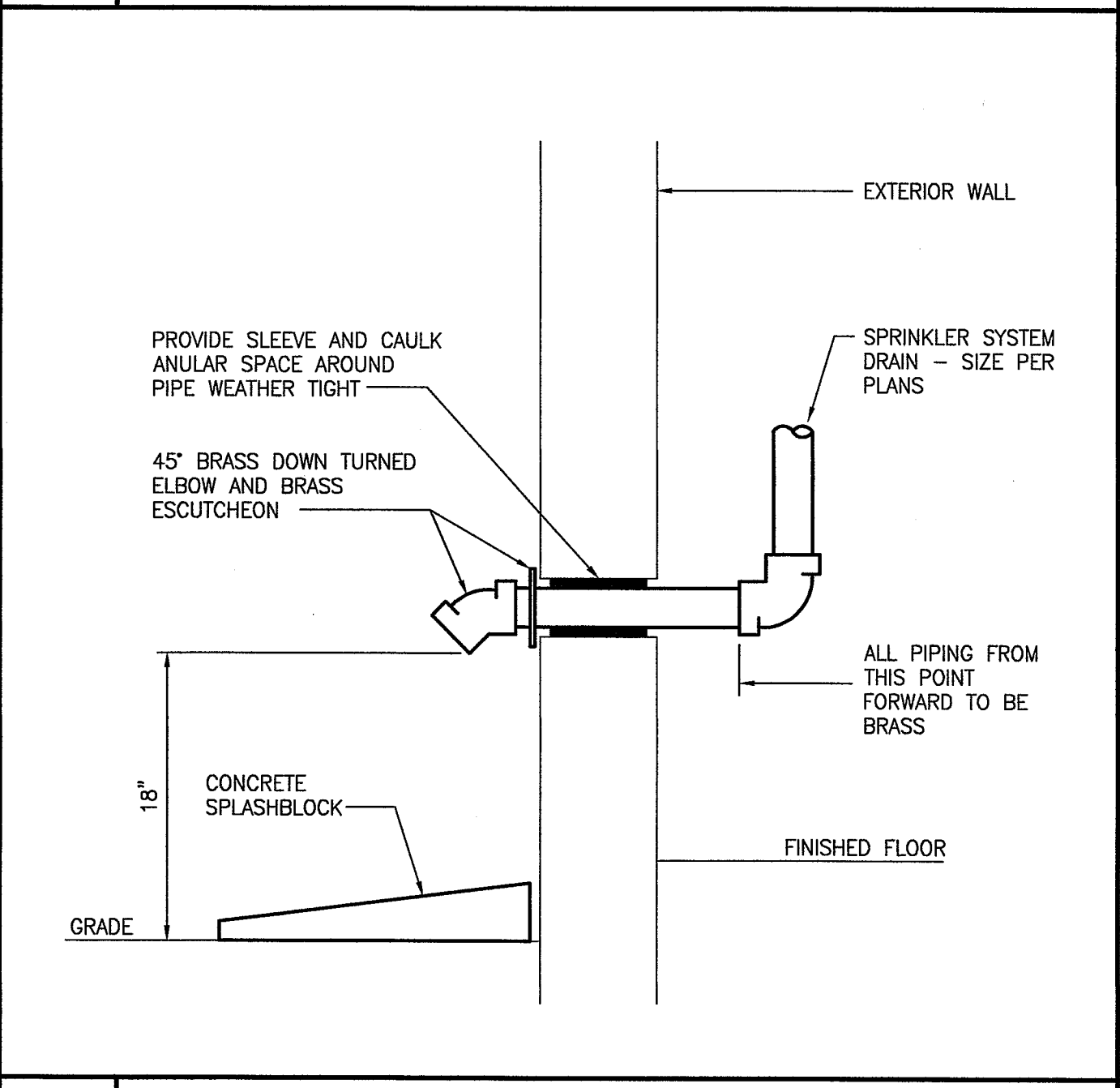

D7 SPRINKLER DRAIN
NTS

100% CONSTRUCTION
 DOCUMENT SUBMISSION
 20-JUNE-2014
 FULLY SPRINKLERED

Revisions	Date
0	20-JUNE-2014
100% CONSTRUCTION DOCUMENT SUBMISSION	

CONSULTANTS:

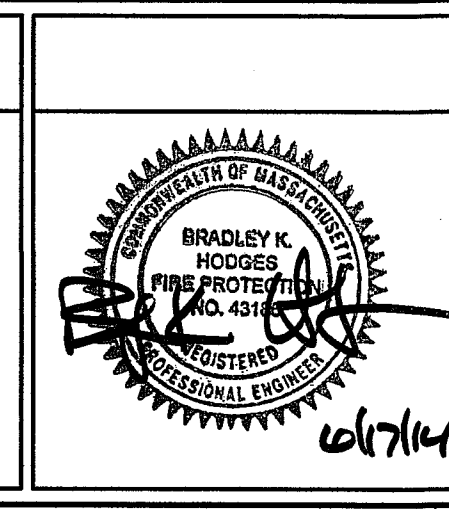

ARCHITECT/ENGINEERS:
 ARCHITECTURE One Dundee Park Suite 4
 Andover, Massachusetts 01810
 ENGINEERING tel. (207) 772-3846
 PLANNING fax. (207) 772-1070
 INTERIORS www.smrinc.com
 ENERGY SMRT Project Number - 13006

Drawing Title
 DETAILS
Approved Project Director
 VAPAHCs PLANNING AND ENGINEERING

Project Title
 VAMC BROCKTON
 LIFE SAFETY RENOVATIONS
Location
 BROCKTON MA
Date
 20-JUNE-2014
Checked
 BKH
Drawn
 KDD

Project Number
 523-395
Building Number
 5
Drawing Number
 05.FP501
 Dwg. 284 of 310

Office of Construction and Facilities Management
 Department of Veterans Affairs