

BOTTLE COMPARTMENT CENTERLINES AND VERTICAL RODS REF

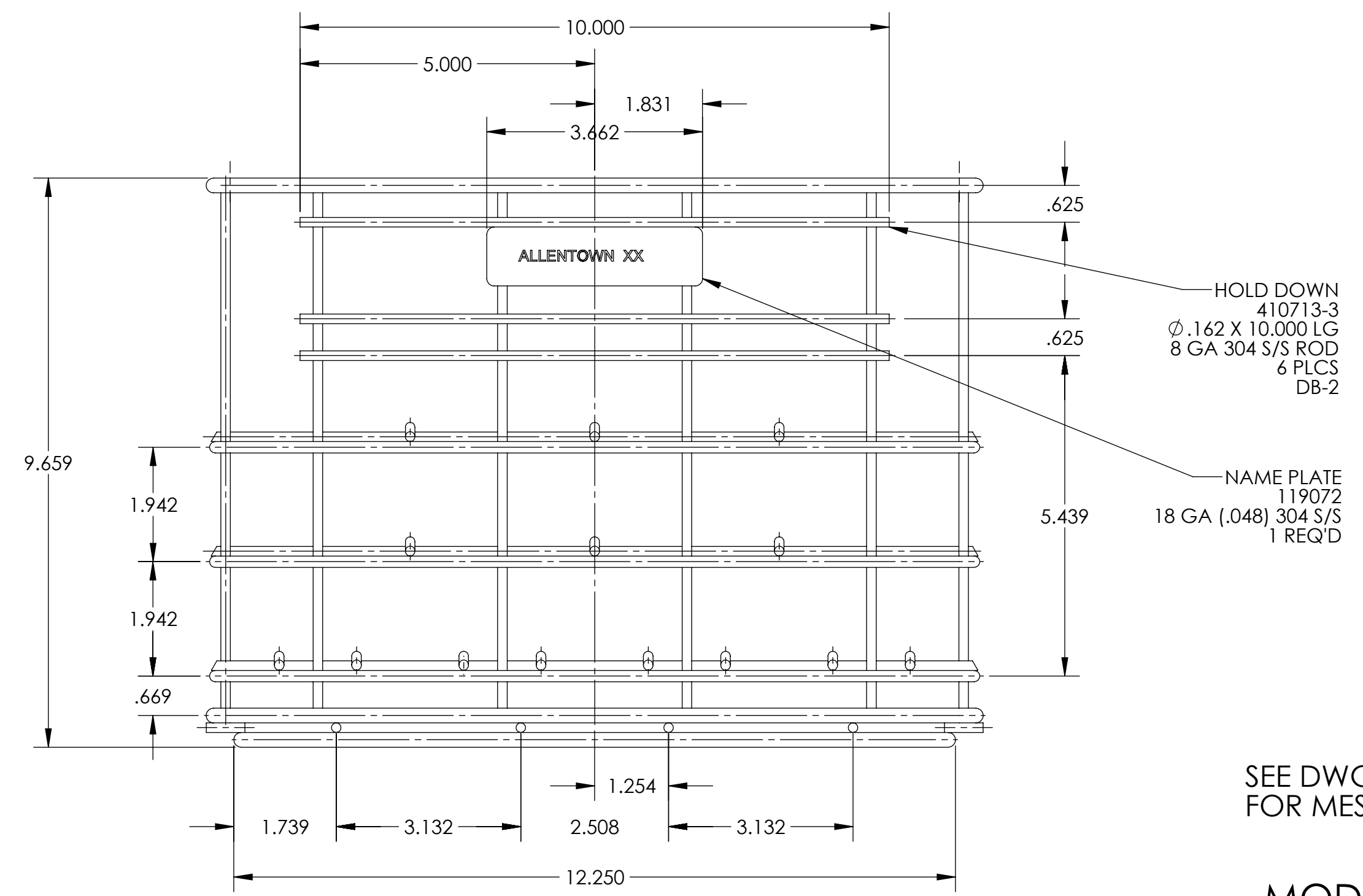
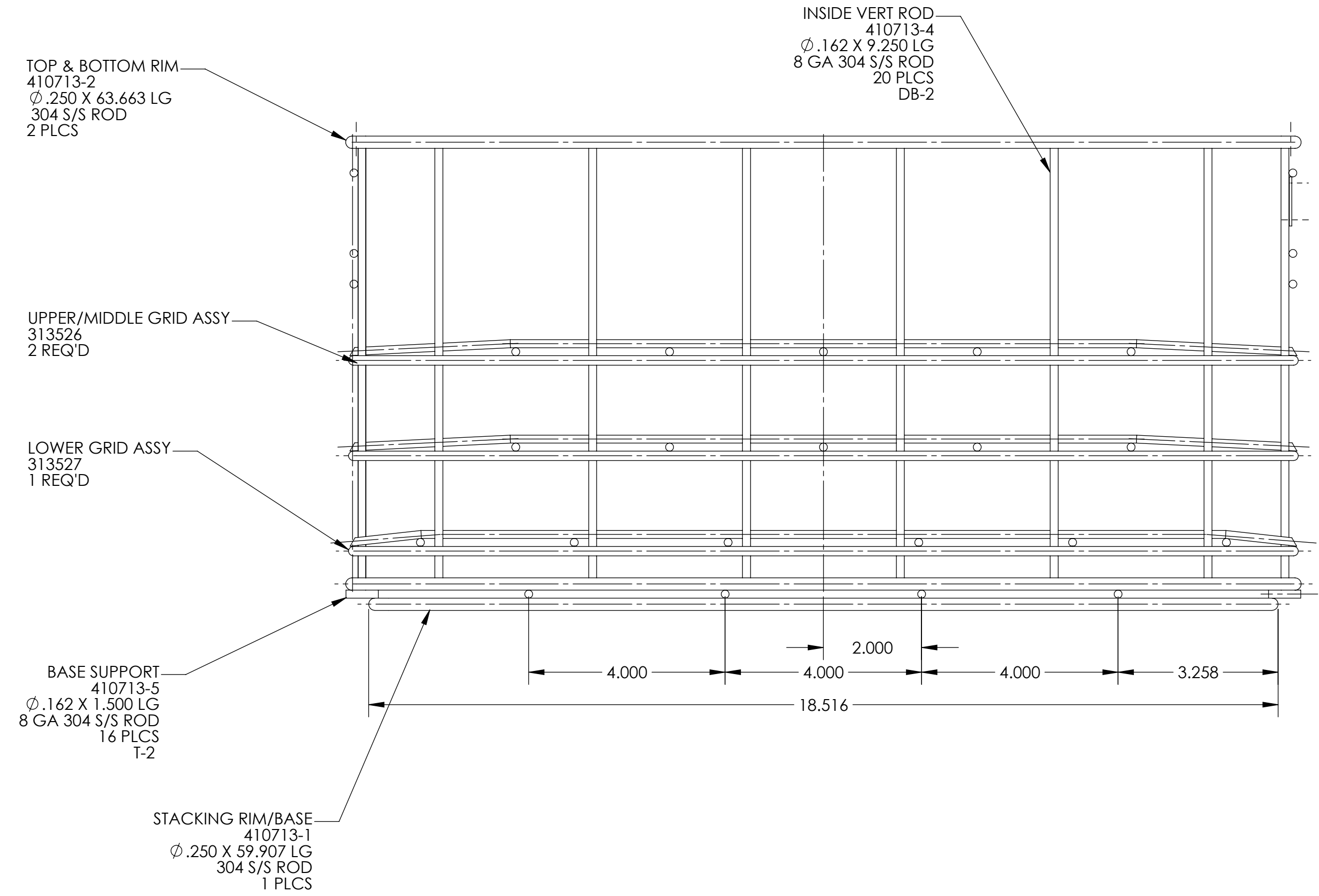
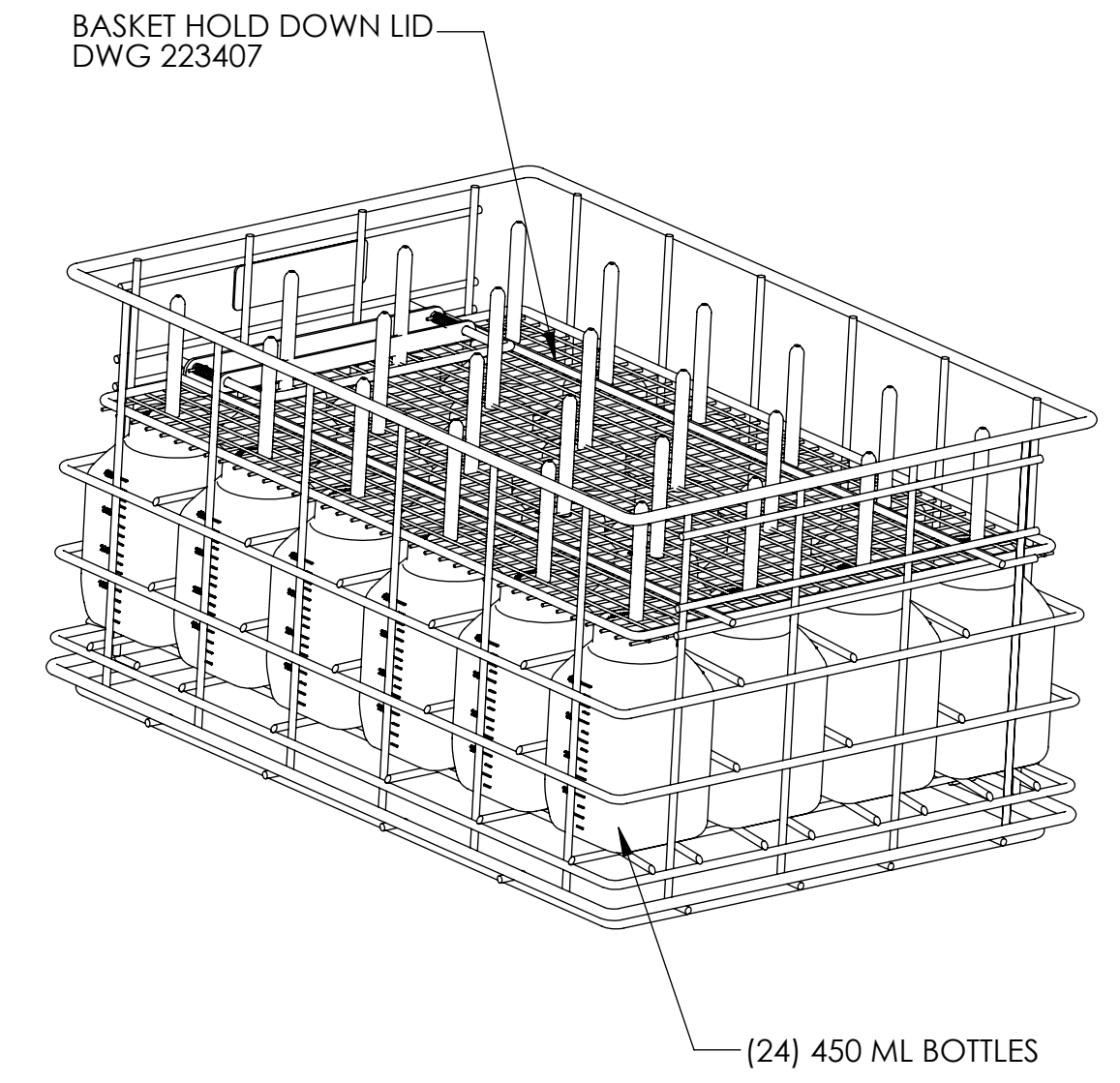
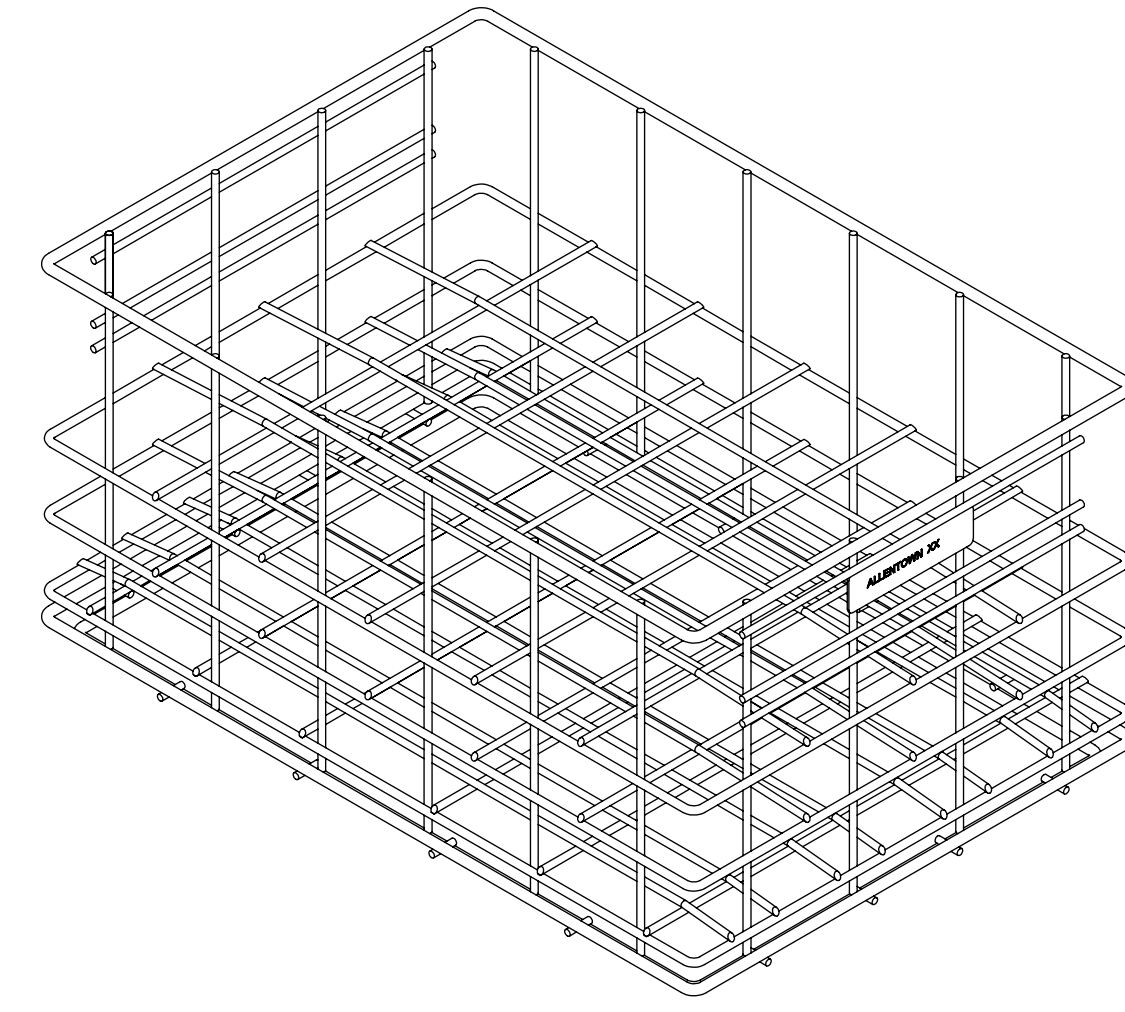

SEE DWG 223407, SO #13582 FOR MESH RETAINER LID

MODEL #BB24450M

<small>PROPRIETARY AND CONFIDENTIAL</small> <small>THE INFORMATION CONTAINED IN THIS DRAWING IS THE SOLE PROPERTY OF ALLENTOWN INC. ANY REPRODUCTION IN PART OR AS A WHOLE WITHOUT THE WRITTEN PERMISSION OF ALLENTOWN INC. IS PROHIBITED.</small>	<small>DRAWN</small> DK <small>CHECKED</small>	<small>DATE</small> 5/14/2012 <small>DATE</small>	
	<small>MATL</small> <small>A.D.D.</small> <small>FINISH</small> ELECTROPOLISH	<small>TITLE</small> 24 COMPARTMENT 450 ML BOTTLE BASKET	
<small>(UNLESS OTHERWISE NOTED)</small> <small>SHEARING: ± 0.10</small> <small>FABRICATION: ± 0.15</small> <small>WELDING: ± 0.02</small> <small>ANGLES: ± 1°</small> <small>DIMENSIONS IN (MM)</small> <small>ALL S.E. AND BURR FREE</small>	<small>REV</small>	<small>SIZE</small> DWG NO 410713	<small>SHEET 1 OF 1</small>

SW: JINYI OF FBAS/SW, 50113981, 10/24/2013 04:56